

Underwater Photography

a web magazine

Feb/Mar 2003



Nikon D100 &

Subal D10

Nikon 12-24mm

Inon Z-220

Colour filters

St Vincent

Cornwall

Crocodiles

Mating mandarins

Aquariums

Antibes winner

Classifieds

What links these sites?



Turn to
page 10
to find out...

Underwater Photography

a web magazine

Feb/Mar 2003

e mail uwp@uwpmag.co.uk

Contents

4 **Editorial**

7 **Readers Lives**

8 **News, Travel & events**

11 **New products**



16 **Nikon D100 & Subal D10**



by Alex Mustard

23 **Colour filters**

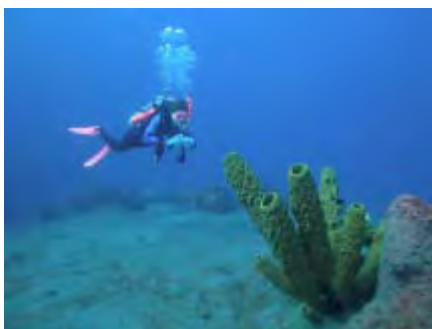

by Peter Rowlands

28 **Inon Z-220**



by Mark Webster

33 **St Vincent**



by Deb Fugitt

40 **Cornwall**



with Mark Webster

Cover photo by
Jurgen & Anne Brauer

49 **Crocodiles**



by Kelvin Aitken

55 **Mating mandarins**



by Shaun & Beth Tierney

58 **Aquariums**



by Jurgen & Anne Brauer

64 **Antibes winner**



by Alex Mustard

68 **Classifieds**

When I started UwP it never occurred to me that I would have to write an obituary but news of the death of Jim Church has saddened the underwater photography community and led to many glowing tributes to the master teacher.

It will always be a regret of mine that I never got to meet Jim in person but we corresponded occasionally via e mail and I read his various postings on the UWPhoto forum.

Jim was a natural teacher and I doubt if there's an underwater photographer of my generation who didn't read and learn from his excellent books on underwater photography. He had a way of explaining even the most complicated theory in terms which were easy to grasp. I think his book on Composition is a classic example.

Nearly all of the tributes mention the warmth of the man, always willing to impart his vast knowledge for the good of others and to take time to listen and respond helpfully to questions he must have heard hundreds of times before.

Jim may no longer be with us but his wisdom and spirit will live on in our lives.

Last year he posted his latest list of "Churchisms" on the UWPhoto forum and I reprint it on the next page in his dear memory.

Editorial

Hyperlink help needed!

I am reliably informed that I can build "hyperlinks" into UwP so that, if you are on line, you can click on the link and it will take you to the web site or create an e mail message.

Now I may be reliably informed but, on this one, I'm also mentally challenged as I can't seem to get hyperlinks to work so would any good UwP reader who knows how to set up hyperlinks using Adobe Pagemaker on an Apple Mac please get in touch?

The reason why I'm keen to set up these links is because it would then be possible for advertisers to monitor the number of times their site is visited from a UwP link and so give them an indication of how successful their advert is in creating a positive response.

Advertisers in conventional magazines often include a reference code which tells them where the customer saw the advert but UwP should be able to go much further than that and provide advertisers with much more information.

So, please, if there is anyone out there who can help, I'd love to hear from you.

Digital dilemma

I'm sure there's a lot of underwater photographers contemplating a leap into the digital age and they will learn a lot from Alex Mustard's excellent review of the Nikon D100 and the Subal D10 housing in this issue.

Comparing 35mm film performance to digital is not yet on an equal footing but it is getting very close. When a "full frame" 35mm chip is available at a reasonable price we will have a similar depth of field but with a much improved white balance performance and that has to be worth the wait.

In the meantime the imminent arrival of the Nikkor 12-24mm lens will give the equivalent of an 18-36mm zoom with the Nikon D100 which has a smaller chip than the 35mm format. This will be a very attractive lens to underwater photographers who tend to use much wider lenses than land photographers and will help to justify the D100 format as sufficient for the majority of underwater photographers needs.

The file sizes the D100 can produce will easily reproduce up to A4 in a quality magazine and probably larger so, as such, it already provides the quality needed but the advent of the 35mm full frame chip is still the light at the end of the digital tunnel.

Peter Rowlands
Editor

peter@uwpmag.co.uk

Underwater Photography magazine

is published by
PR Productions

13 Langley Avenue, Surbiton, Surrey KT6 6QN
Tel & fax 00 44 (0)208 399 5709

THE RULES OF CHURCHISM

(in random order)



01. Go potty every chance you get.
02. Stay out of the sun.
03. Avoid making promises.
04. Never give undeserved gifts or praise.
05. Beware of undeserved gifts or praise.
06. Winning an argument may lose a friend.
07. Never argue if you have nothing to gain.
08. If you must do battle, fight with someone else's troops.
09. Nothing is what it seems to be, and nothing turns out as expected.
10. It's easier to change a plan than to have no plan.
11. People don't change, they get older.
12. Nobody can predict the future.
13. What's here today is gone tomorrow, but nothing really changes.
14. Don't say what you don't want repeated.
15. An erect penis has no conscience.
16. Never loan what you can't do without.
17. Never borrow what you can't pay for.
18. Have a check list and follow it.
19. Never dive in water below 80 degrees F.
20. Always pee in your dive suit. (There's no such thing as a dry suit.)
21. A fish moves faster than a camera shutter.
22. Don't piss off the golden goose.
23. There's no problem you can hide from.
24. Imaginative minds can always find a new problem or complaint.
25. Rules are made to be wondered about.
26. When asking a group to assemble, no time is a good time.
27. There's no such thing as a water-proof camera, strobe or housing.
28. If you were smart enough to hide your stupidity, you wouldn't have to.
29. The reason you dive is to get away from meaningless conversation.
30. Always drink upstream from the herd.
31. If you can't have a good time, be a good time.
32. If someone else will do a dirty job, let them.
33. Don't ask for it -- you just might get it.
34. Whatever lens you choose, it won't fit your subject.
35. Always hang your dripping wetsuit over someone else's locker.
36. Don't shoot in the ocean what you can shoot in a pool.
37. "Good enough" depends on whether your position resembles William Tell's or that of his son.
38. Never fart if you are the first person to take a seat in first class.
39. Heed George Washington's advice: avoid entangling alliances.
40. Avoid diving in Russian submarines unless you have a pony bottle.
41. No matter what happens, somebody will find a way to take it too seriously.
42. A person who is nice to you, but is rude to the waiter, isn't a nice person.
43. Trust everyone, but cut the cards.
44. If at first you don't succeed, try viagra.
45. Never give yourself a haircut after three margaritas.
46. Work is good, but it's not that important.
47. Be nice to your friends. You never know when you will need them to empty your bedpan.
48. Nap whenever possible.
49. It's better to have something and not need it, than to need something and not have it.
50. Famous last words: "Oh, don't worry about that; it'll never happen."
51. When all is said and done, much more will have been said than done.
52. If you can't take good photos, go to Church and pray.
53. Establish the location and supply of TP before the need arises
54. Another person's lack of preparation or reading of directions isn't your immediate emergency.
55. To start endless conversations, ask any group about o-ring grease.
56. Exercise daily, and you will live five months longer--in a \$5,000 a month nursing home.

international journal of the sea

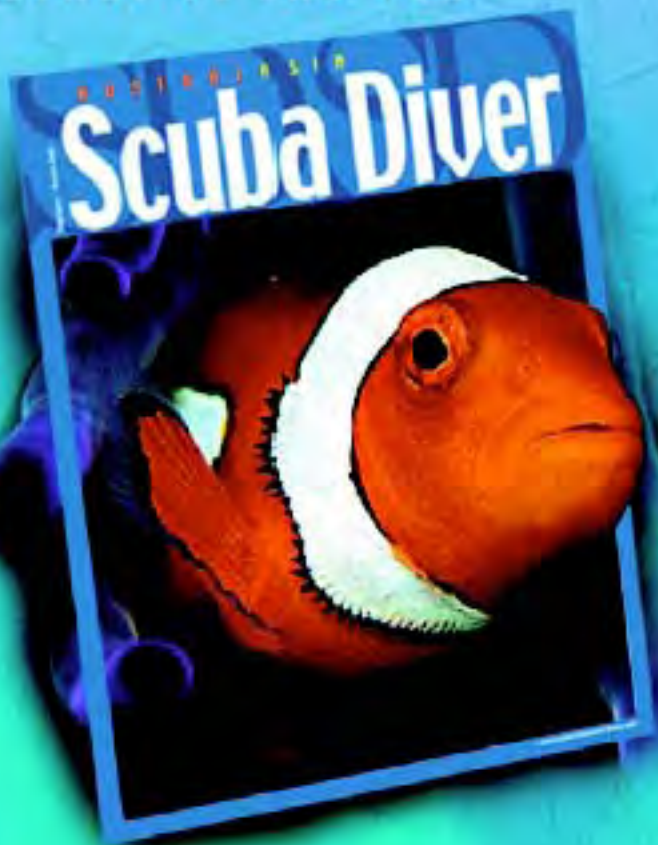

Australasia's premier dive journal, all the best Asian & Australian destinations, stunning photography, portfolio's of the masters, digital photography, new gear and more.

Subscribe Now! Our photography portfolios have featured Stephen Frink, Doug Perrine, Michael AW, Stephen Wong, Constantinos Petrinos amongst others, all featuring their shooting secrets. Photo contests galore. Check-out the Nikon/ScubaDiverAustralasia Underwater Photography Contest, plus look for Celebrate the Sea Marine Imagery Festival 2003 in Kuala Lumpur, Malaysia, August 2003, more than US\$50,000 in prizes

Check out www.scubadivermag.com & www.celebratethesea.com

International journal of the sea **ScubaDiverAustralAsia**

Sub
Draws

www.sipadan-resort.com

www.sipadan-mabul.com.my



Sipadan Island Resort 7 days/6 nights or 10 day Package or Langkan Island

Sipadan-Mabul Resort 5 days/4 nights-Mabul Island

Duba - Sea Scooter www.duba.com

OVERSEAS ANNUAL SUBSCRIPTION, FOR AUSTRALIA & ASIA PLEASE CONTACT US FOR RATES

PAYMENT METHOD

Special
Offer

- ONE Year Subscription
US\$30 / €30
- TWO Years Subscription
US\$50 / €50

My Name / Gift for _____

Address _____

Country _____ Postal code _____

Tel _____ Fax _____

Email _____

- \$S cheque or bank draft, made payable to
Asian Geographic Magazines Pte Ltd.

or
Debit my credit card for the required amount.

- Visa Mastercard Amex JCB

Cardholder's Name _____

Card No.

Expiry Date _____

Signature _____

Send to: Asian Geographic Magazines Pte Ltd 36 Jalan Puteh, Johari, Singapore 278158
or Fax: 65-62912068 this form or email subdetails@stangeographic.org

A lurker responds

I have just read the Dec/Jan no.10 issue of the magazine. I have been enjoying the mag ever since issue no.1.

You seem to be a little mystified by the lack of feedback you have from your readers.

Don't be; as you no doubt know, the web is full of 'lurkers'.

You hit the nail of one of the reasons on the head when you say that "because it is free, people don't like to criticise."

True, but it is also very obvious that you know your chosen field inside out, and that the magazine is very professionally put together, and it may well be the definitive magazine for uw photography, and....

Well, you get my drift. There is not too much to criticise about the publication.

Please keep up the good work.

Will Timson

Your favourite dive guide

We have dived in various places and with a 'wide' variety of guides. It is definitely our experience that a great guide/divemaster can transform a dive site. Conversely a bad one can ruin a great site.

To this end we reckon that you might be able to persuade photographers or whoever to write in with a short piece about their favourite. Everyone knows Larry Smith, most seem to dive with Idrus at NDC and I'm sure there are more elsewhere.

W&D Posslethwaite

Sounds good to me W&D. I hope your idea is picked up by UwP readers . Ed.

Readers Lives

Beginners wanted

I've just downloaded UWP issue 10, and am amazed to hear that you don't get feed back.

UWP has some nice articles, and some very nice pictures. Obviously no one wants to put bad pictures on display. But a "Beginers" section would be nice. Show us a bad picture, then show us what was done to make it good, that would create enough technical articles to fill things for a while, and THEN, there's composition.... oohh, big subjective subject!

It would be good to see some critique along the lines of "This would be a good picture if..." People like me would probably come along in leaps and bounds then. Being able to identify causes of mistakes is good. And I'm sure your advertisers would like the thought that you were getting through to beginners as well as established photographers.

On another theme, and I KNOW that the whole world is now digital, but what about something on E6 processing? Where can equipment be purchased?

And scanners? Minolta ignored me when I asked them a question so if they cannot be bothered to answer the question why should I buy the scanner? But you may get a different response.

Pete Steggle

All good ideas which I will follow up except the scanners which I think is a bit "off topic". Ed.

A worldwide magazine from local people

Regarding your UWP on-line magazine. I note that you say you have little feedback. I do download it and very much enjoy the articles. However, like most magazines after a while the format settles and inevitably the same advertisers and contributors occur in a number of issues. It is difficult to see how to overcome this as there is a relatively a select pool of high profile photographers to draw from.

As an occasional photographer - e.g. a couple of weeks a year - who probably manages half a dozen half-decent shots each year it is hard to see what I could contribute.

However - given that it is an E magazine with no geographical limits it might be nice to see articles from local photographers around the world giving a taste of their local photography opportunities and perhaps some contacts and guidance on finding photography friendly diving facilities and sites, best times to visit, potential buddies or guides with local knowledge etc.

Regardless, I wish you every success with future publications and hope that they continue for years to come.

Ralph Anderson

Good idea Ralph. I would welcome such articles. Ed.

UwP welcomes your feedback. E mail feedback@uwpmag.co.uk

News, Travel & events

Beneath the Sea 2003 proudly announces the Jim Church Award

Beneath the Sea 2003 proudly announces the Jim Church Award for excellence in digital photography.

As many of you know, Beneath the Sea 2003 added this year a digital category in addition to the David Doubilet Award for excellence in underwater photography and the Stan Waterman Award for excellence in underwater videography.

As many of you also know, Jim was a long

time supporter of Beneath the Sea. His workshops were always among the most popular and his presence enhanced the entire weekend.

In honor of Jim's memory, BTS is proud to name its newest underwater photography Award after him. The award will be presented at the Undersea Film Festival (Saturday, March 29, 2003 8:00 to 10:00 pm). The Film Festival will be MC'd by Phil Nuytten and special guest Al Giddings.

For more information www.beneaththesea.org

Mozambique

**18th May - 27th May 2003
with Gavin Anderson and Trevor Krull**

Mozambique is a place where one can find world class diving along a seemingly endless coastline, flanked by beautiful white sandy beaches and coconut palms. Much of the diving potential of Mozambique's waters remains to be discovered and the more adventurous traveller will be rewarded with some truly unforgettable experiences.

Diving off Inhambane is rated as the best in Mozambique. From a kaleidoscope of multicoloured anthias, corals and anemones, to the great plankton-feeding Manta Rays and Whale Sharks, each dive site offers something special.

Accommodations will be at Guinjata Bay Lodge and Pomene Bay Lodge. Pomene Bay lodge is known for its friendly atmosphere and good home cooking and Guinjata for its great bar! Both are located amongst coconut groves next to pristine white beaches and overlooking the warm waters of the Indian Ocean.

This will be Gavin Anderson's fourth trip to Mozambique, and although no formal underwater photography teaching will be available, Gavin will certainly have his camera with him and is always happy to pass on tips of the trade or discuss any photography problems. Trevor Krull now lives in South Africa, but he lived in Mozambique for two years while he operated a dive centre and pioneered much of the diving in the areas we will visit.

For further details please contact Divequest www.divequest.co.uk

Michael AW's Diving Tour 2003

**Lembah Strait July 2003
Galapagos October 2003
Antarctica November 2003**

Michael AW & ONE expeditions cater exclusively for wildlife enthusiasts and underwater photographers. 90 percent of dive sites are thoroughly surveyed and proven popular with photographers and bio-diversity scientists. Because you will wish to be familiar with the animals and learn more about their behavior, some sites are dived 2-3 times. Photographers will have plenty of opportunities to reload film and change lenses. Our land visits during our Galapagos expedition are at least 3 hours.

We restrict our numbers, which improves the quality of your marine life experience - animals are less likely to be frightened away. Photographers will have ample space for the optimum photo opportunities. Because we want you to enjoy the experience both underwater and above, we only select first class operations for accommodation, dive operations and live-aboards. However some of the best diving is in remote corners of the world, the operation may not be 5-star, but the service and diving will be.

To book on any of the tours email one@michaelaw.com or one@michaelaw.com for application form.

Isla de El Hierro competition

The 7th Open Internacional Fotosub Isla de El Hierro will take place on 26th - 29th of March 2003.

This is an annual international open competition which started in 1996 in the Marine Reserve located in the small island of El Hierro (Canary Islands), one of the most appreciated diving zones for European divers.

It is organised by the Tourist Board of El Hierro Island and Carlos Minguell (twice World Champion of Underwater Photography) is in charge of the Technical Direction.

The Open Internacional Fotosub Isla de El Hierro consists of two days of competition, with a total of 4 dives in the best dive sites. A collection of six slides (freely selected by the participant, without any obligatory categories) is presented by each participant. A Jury composed by prestigious and experienced underwater photographers announce the results on the last day.

There are big prizes for the best entries and also other special prizes for spectacular images depicting the uniqueness of the El Hierro waters

and marine life.

This year there will be a total of 18000 Euros of cash prizes.

Entrants must register by 3rd of February, but bear in mind that the number of participants is limited to 24. For any enquiries about the competition, please, write to the Technical Direction Department

Openfotosub@ocean-photos.com.

For more information visit

<http://www.openfotosub.com>

The Sardine Run - South Africa

6th-12th June 2003

As seen on Blue Planet and National Geographic. Photographer's paradise! A must for all adventurers, divers & snorkellers.

Accommodation:

<http://www.mbotyi.co.za/index.html>

<http://www.mbotyi.co.za/index.html>

Research websites:

http://www.biganimals.com/sardine_run.htm

Contact Walter at watersports@icon.co.za

<http://www.africanwatersports.com>



Bahamas
Turks & Caicos
Tobago, Dominica
Bonaire, Venezuela
Little Cayman, Cozumel, Belize
Honduras, South Africa & Mozambique
Thailand, Sipadan, Mabul
Layang Layang
Derawan & Sangalaki
Bali, Komodo, Wakatobi,
Manado, Kungkungan Bay
Palau, Yap, Truk
Bikini Atoll
Australia's Coral Sea
Papua New Guinea, Solomons
French Polynesia
Fiji, Hawaii, Sea of Cortez
Revillagigedo Islands
Cocos & Malpelo Islands, The Galapagos
Wrecks of Palau

Plus Underwater Photography Group Trips and Courses with leading photographers:
Martin Edge, Linda Dunk, Malcolm Hey, Charles Hood, Gavin Anderson

DIVEQUEST

The Ultimate in Underwater Photography Adventures

ATOL Protected 2937

Telephone: 01254-826322 or e-mail divers@divequest.co.uk website: www.divequest.co.uk

What links these sites?



London's premier watersports centre

11 - 14 Northumberland Avenue

London, WC2N 5AQ

Tel: 020 7930 5050

Fax: 020 7930 3032

email: info@oceanleisure.co.uk

New products

Light & Motion Titan D100 housing

Light & Motion continues to broaden the Professional Digital Photography line with the entrance of the Titan D100 SLR Photo Housing.

The Titan D100 is designed specifically for the Nikon D100 6.1 mega-pixel digital SLR.

The D100 supports Compact Flash and Microdrive which provide massive storage capabilities that enable the user to save hundreds of high-resolution images.

The Titan D100 Housing includes fingertip



access to most camera controls using both mechanical interfaces, as well as infrared through the newly designed Smart Grips.

For further details surf to

www.uwimaging.com

Sea & Sea DX5000 Housing for the Nikon CoolPix 5000

The DX5000 has the size and weight of a compact camera, with the functionality, flexibility and resolution of an SLR system. Utilizing the Nikon Coolpix 5000, this system combines standard Sea & Sea features such as underwater changeable lenses and ergonomic design with Nikon's high resolution compact digital camera. With a large shutter release and buttons for almost every camera function, the DX 5000 housing lets you take advantage of all the great features that Nikon has put in to the Coolpix 5000.

Controls include: Shutter release, On/Off, Zoom, Focus, Flash mode, Focus zone control/ Menu access, AF lock, File size, Quick review, Menu, Monitor.

This rugged housing is



constructed of ABS and polycarbonate plastic for corrosion resistance and lightweight. Designed with flexibility in mind the housing will accept all of the current line of conversion lenses for the MMIII camera. Super-wide, 2T and 3T macro are available and changeable underwater. A newly designed .056 wide conversion lens is also available for use on the housing. The housing accepts

all Sea & Sea strobes with either optical sync connections or standard 5pin "N" type cords. A tripod socket is provided for mounting on the Sea & Sea base stay for use with external strobes and arms.

Depth rating 60meters (195 feet).

For further details surf to

www.seaandsea.com

New Lenses For Olympus PT Series

UN, who design and manufacture the popular PT housings for Olympus consumer digital cameras, have released two new lenses.



The first is a macro lens to allow higher magnification than the camera's own built-in close-up facility provides. The new lens is perfect for tiny critters like nudibranchs and for detailed stills of corals.

The wide angle lens is a 0.58 reducer which provides a much greater field of view than the wide setting on the camera's own zoom. Digital cameras usually offer poor wide angle capability which is further impaired by being used



underwater behind a flat port which narrows the angle by about a third. Using the UN wide angle lets you get closer to your subject to reduce the water

column and improve sharpness. It's also ideal for working in tight spaces like the confines of a wreck.

The UN lenses are made of glass for the best possible image quality. Both are wet lenses that can be easily attached and removed as required during the dive. Because they are manufactured by UN they are perfectly matched to the Olympus camera and housing range.

Ikelite housing for Olympus C-50

This Olympus digital camera features 5.0 million pixel resolution in an incredibly small size. The housing provides controls for all camera functions, and the LCD monitor is easy to see through the housing back.

Sliding the camera door open powers up the camera, then drop it into the housing for a fun and satisfying experience.

The housing is molded of corrosion-free clear polycarbonate and operates safely to 150 feet. The flash built into the camera operates fine in the housing.

Optional aluminum base plate and single handle provides near neutral buoyancy and allows attachment of optional SubStrobes.

The flash built into the camera can provide very fine photos, but an optional DS series strobe placed farther from the lens improves the photographs by reducing the illumination of particles suspended in the water.

For further details, fly to

www.ikelite.com



Nexus D100 housings

Japanese manufacturer Nexus have just announced their housing for the Nikon D100 digital SLR.

Full details are yet to be released but there are control buttons for:

- * Function dial
- * Flash sync mode button
- * Exposure compensation button
- * Shutter release button
- * Power switch
- * Focus mode selector
- * Sub-Command Dial (Aperture)
- * Main-Command Dial (Command)
- * Multi selector
- * Protect button
- * Enter button
- * Delete button
- * Focus area lock switch

UwP hopes to do a full review of this housing in the April issue so please keep tuned for further announcements.

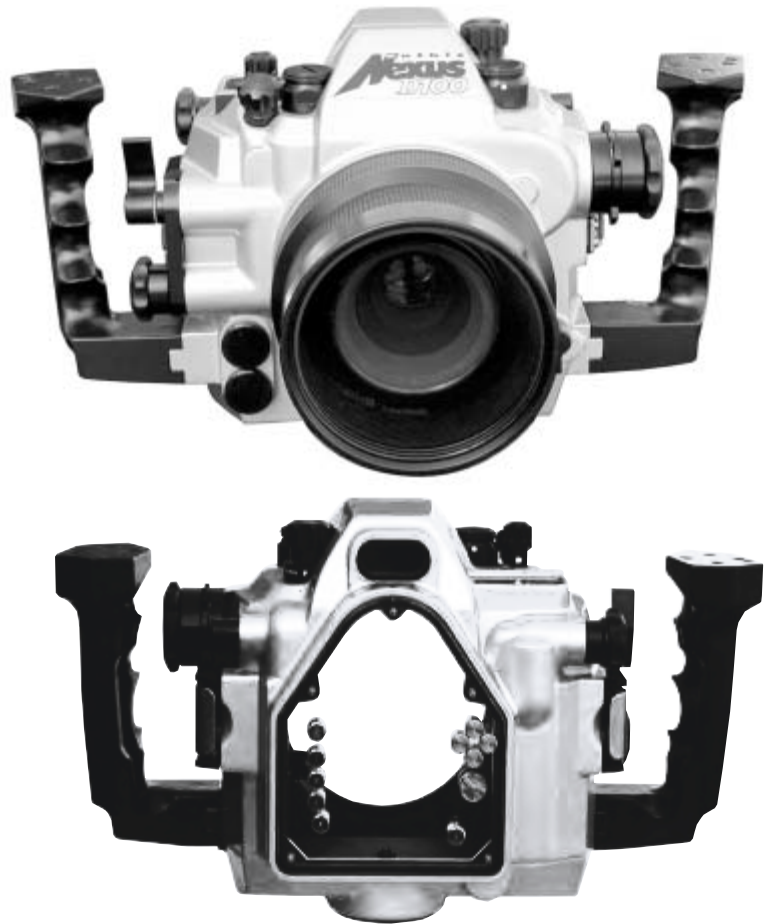

Fantasea CP- 4 housing for Nikon Coolpix 4300 and 885



The CP- 4 SCUBA Housing for Nikon Coolpix 4300 (4MegaPix) and Coolpix 885 (3.2MegaPix) Cameras should be available in March 2003

It is depth rated to 30

meters/100 ft and is purpose designed with full automatic and manual controls.

There are controls for Tele/ Wide angle zoom, Shutter Speed , Aperture, Macro focus and

Quick review and delete options

For more product information visit

www.fantasea.com

DX Zoom-Nikkor 12-24mm

TOKYO-Nikon Corporation is pleased to announce the development of the first DX Nikkor lens - the AF-S DX Zoom-Nikkor 12-24mm f/4G IF-ED. (18-36mm in 35mm (135) format equivalent with Nikon D1-series and D100 digital SLRs.

This will be the first truly compact, lightweight AF-S ultra-wideangle zoom lens designed exclusively for use with Nikon digital SLR cameras, and is scheduled to be released in the spring of 2003.

Since the D1, Nikon has employed a 23.7 x 15.6mm size image sensor in its digital SLRs. It was designed specifically for Nikon digital SLR cameras, and provides a wide dynamic range which makes it easier for the camera to process captured images. At present, this sized image sensor features extremely well-balanced performance that is not possible with sensors of other sizes. Needless to say, it also offers high cost-performance.

However, when a 35mm (135) format lens is used with a Nikon digital SLR, the picture angle is approximately 1.5 times the focal length of the lens (35mm [135] format equivalent). This characteristic proved to be advantageous when producing super-telephoto lenses (e.g. 600mm becomes 900mm) and fast telephoto lenses (e.g. 400mm f/2.8 becomes 600mm f/2.8). In the case of ultra-wideangle lenses (e.g. 14mm becomes 21mm), though, it turned out to be a liability as it became difficult to produce truly



compact lenses.

To resolve this problem, Nikon has adopted a new lens design specifically for Nikon digital SLRs, featuring a smaller image circle. The combination of reduced picture angle and smaller lens diameter have made possible compact body design and high cost-performance for ultra-wideangle lenses.

Nikon digital SLR users can look forward to exciting additions to the lens lineup, as the new lens design can also be applied to high-power zoom, fast (large aperture) and other such high-performance lenses.

The AF-S DX Zoom-Nikkor 12-24mm f/4G IF-ED, the first DX Nikkor lens, is an ultra-wideangle 2x zoom lens featuring a focal length starting at 12mm (18mm for D1-series and D100) for greater covering power.

The lens also incorporates Nikon's exclusive built-in SWM

(Silent Wave Motor) for fast, quiet autofocus operation. Superior overall optical performance is achieved by a new optical design featuring ED (Extra-low Dispersion) glass elements for minimized chromatic aberration, and aspherical lens elements for low distortion. The rounded diaphragm opening makes out-of-focus elements appear more natural.

This lens is being developed for professionals and advanced amateurs currently using Nikon D1-series and D100 SLRs - as well as prospective digital SLR users - who desire more lenses to choose from, particularly in the ultra-wideangle focal range.

Note: DX Nikkor lens is fully compatible with the Nikon D1-series and D100 cameras.

The British Society of Underwater Photographers (BSoUP)

The British Society of Underwater Photographers (BSoUP) was formed in 1967. Today it has over 300 members and is the largest underwater photographic society in Britain.

When it was formed, the prime objects of BSoUP were to create a forum for the exchange of ideas and information about underwater photography and put the activity on the map. Today, the Society is still dedicated to encouraging and developing underwater photography in all its aspects, from slides to cine and video. Its members vary from divers who have just started to take underwater photographs to eminent professionals who lead the world.

The basic needs of members for information and contact with other enthusiasts is catered for in

several ways.

General meetings are held in London on the third Wednesday of every month. At these meetings a particular aspect of underwater photography is discussed to help the less experienced. Led by very experienced, award winning photographers, these discussions are followed by a competition, the subject of which varies from month to month. These competitions are open to all members and provide an opportunity for those competing to see how their work compares to that of others.

The main event of each meeting is a presentation by an individual or small group, either members or invited guest speakers. These presentations can range from underwater

photographic expeditions to specialised techniques for certain types of underwater photography and talks by renowned personalities.

The meetings also provide an informal social environment where members can exchange ideas, sell unwanted equipment, arrange expeditions and enjoy a drink at the bar.

Additionally the Society produces its own newsletter 'in focus', which is sent to all members, every four months. This full colour newsletter includes news of meetings and competitions, items on underwater photography and expeditions and second hand equipment for sale.

<http://www.bsoup.org>

Barefoot Luxury in Fiji!

Immerse your senses in azure seas, in the beauty of Fiji's renowned soft coral gardens, in the casual luxury of Matangi.

Relax with friends, hike, kayak, dive, photograph, do nothing. Celebrate a honeymoon, get married, dine by candlelight on the beach.

Matangi Island Resort
... for divers who want the most from life
Fiji Islands

uw@matangi-fiji-diving.com

www.matangi-fiji-diving.com

Has the future arrived?

First impressions of the Nikon D100 underwater in a Subal D10

By Alexander Mustard

Digital is the future of underwater photography. There is little doubt. It is clearly no longer a question of if. The question is when.

In 2002, Nikon released the D100 digital SLR and it has been greeted by a furore of activity from housing manufacturers. In contrast, housings for Nikon's higher specified D1 series were conspicuous by their (almost total) absence. But the cheaper, lighter, smaller D100 has already been promised homes from the likes of Aquatica, Hugyphot, Ikelite, Light and Motion, Sea and Sea, and the subject of this review, Subal. Has the future arrived?

My aim in this article is to assess the D100 from the point of view of someone who is already shooting a 35mm Nikon SLR underwater and is thinking about digital, because I see them as the most likely client for the D100 (for one thing they will already have the lenses). This article represents my first impressions. I have not yet used a digital TTL flashgun with the housing underwater, nor have I taken it on a typical diving trip. But at a time when SLR photographers are taking digital increasingly seriously, I hope you find my initial experiences valuable.

The camera

The D100 will look and feel familiar to any modern Nikon SLR user. Although this camera shares its number with the F100



it is more closely related to the F80. It is a curious mix of old and new, for example, it has a traditional F lens mount on the front and modern LCD monitor screen and boat load of buttons on the back. Familiar are Nikon's four exposure modes: P - Program, S - Shutter Priority Auto, A - Aperture Priority Auto and M - Manual. The three exposure metering modes are conventional too: matrix (3D 10 segment), centre weighted and spot. If you are used to a Nikon you can switch on the D100 and get snapping immediately.

Inside the D100 it's all new. Film has gone; in its place is a CCD with 6.1 million effective pixels (Megapixels or Mp), which produces images of just over 3000 by 2000 pixels. To put this in terms that might make more sense - this is equivalent to scanning your slides at 2200 dpi,

or a high quality (300 dpi) print size of 25.5 cm by 17 cm.

All digital SLRs all have an astonishing wallet emptying ability at purchase. The D100 is £1600 in the UK. But for trigger-happy photographers the lack of film costs produces a considerable reimbursement. I have had my D100 for a little over 3 months and have already downloaded 3000 pictures from it (an amount that surprised me). Certainly many of these shots were taken for evaluation, but 3000 pictures is the equivalent of 84 films, which at say £6 to buy and develop is over £500 saved!

The digital images from the camera can be saved onto either a Compact flash card or an IBM Microdrive in one of 5 image formats: RAW NEF (Nikon Electronic image Format), TIFF and three levels of JPEG. The RAW files are the CCD output



warhol.jpg - These pictures show the results of using a grey card for white balance calibration in the pool (under tungsten lights). No filters were used in these shots, all colour adjustment was done by the camera's electronics. a) shows my friend (with typical "Yorkshireman in January" complexion) as he would appear on daylight balanced film; b) is the white balance calibration from the grey card; c & d) are the warmer and cooler auto-bracketed white balance shots, respectively. All: D100 + 17-35mm, 1/15th @ f2.8, 1600 ISO.

and are the highest quality images available from the camera. They can be read in Photoshop with the plug-in supplied with the camera. TIFF files are something of an irrelevance because they take up more space than the RAW files and cannot contain more real information (having been converted from the RAW files by the camera). If you want TIFF files it is best to produce them on your computer after downloading. Most people will find the high quality (fine) JPEGs ideal for most situations. On the 1Gb Microdrive, currently the largest memory card available for the camera, and therefore sure to be a favourite underwater, shooting at 6Mp the RAW format gives 107 shots, TIFF 59 shots, fine JPEG 320 shots, norm JPEG 625 shots and basic JPEG 1200 shots (the

actual number of jpegs will depend the compressibility of the image content).

Unlike most non-SLR digital cameras the LCD monitor is solely a user requested feature for reviewing images and cannot be used as an alternative to the viewfinder when shooting. The monitor has a 9 times image zoom, which is excellent for checking the sharpness of that shrimp's eye! LCD monitors are the sworn enemy of batteries, and by not relying on the LCD during photography the D100 has outstanding battery life. The camera will easily take over a 1000 shots between charges and the claimed 1500 is obtainable when the LCD is used sparingly. Recharging the small, light lithium battery on either 110 or 240 volts takes less than 2 hours.



Mask1.jpg and Mask2.jpg. Correct colours? Digital cameras offer two ways to colourful images artificial lighting or calibrated white balance. The upper image (*mask1*)



The Housing



Like the camera, the Subal D10 will have a reassuring layout to owners of the latest generation of Subal housings. Compared to my F100 housing it is lighter and more compact, but accepts all my existing Subal ports. The camera is mounted in the housing on a removable base tray, meaning it can be whipped in and out in seconds if need be. However, both the lens and image storage card can be removed with the camera still in place. The LCD monitor is very well shaded in the cast aluminium housing, and can be seen easily underwater, which is often a major failing of clear plastic housings.

The D10 has two flash synch sockets, two handles, two strobe arm mounts and a leak detector. The housing provides dials and buttons to all the camera's major controls. There are 25 in all, which must be something of record? The few functions not controlled are far from crucial for underwater shooting! Typical of a Subal, all the housing control dials work immediately, without any modification to the camera.

The housing is only slightly negatively buoyant in the water with a good posture. Unlike digital compacts there is no delay in the shutter mechanism, you press the kill button and you have a picture - it's exactly like a film SLR. The 5 area autofocus is good, but in low contrast situations and when shooting macro I notice that the D100 is inferior to my F100. This is simply because the D100's autofocus is driven by a Multi-CAM 900 module (shared with the F65 and F80), rather than Nikon's better Multi-CAM 1300 (on the F5, F100 and D1 series).

My minor gripes are first that there is no way of telling the position of the function dial from outside the housing without either guessing from

the camera's top control panel display or looking through the viewfinder to see what exposure mode you've selected (which you don't usually do when turning this dial). The second is that the gearing on the sub-command dial (that controls the aperture) is very long and it requires 5 and 3/4 complete revolutions to go from f2.8 to f22 in third of a stop increments. But I am nit-picking. In general the housing is superb.

Lenses

The D100's CCD is smaller than 35mm film (its about the same size as APS film). This means that the viewfinder (which shows 95% of the final image) is also smaller than a 35mm camera's. The Subal housing has an image reducer on the viewfinder to allow the entire screen to be seen through the housing while wearing a facemask. The resulting image is small, but even in a dark pool I was content, I always prefer to see the whole picture. Viewfinders are personal, and I would recommend checking this aspect of the camera is to your taste.

So while the F mount allows all Nikon compatible lenses to be mounted on the camera, the main consequence of the smaller CCD image area is that the effective focal length of lenses is



Sticks.jpg - A branch under the ice. The D100 produces sharp and richly coloured images even in difficult shooting conditions (such as a murky lake, under the ice, in the UK, in January!). D100 + 16mm. Subal D10. No flash. Aperture priority. f6.3 1/60th. ISO 500. White balance - auto.



snail.jpg - For macro the D100 is pretty similar to film. At the moment flash exposure is manual, which is not a problem with stationary subjects and instant image review. Once D-TTL strobes are available this will be solved. The faster ISO (200 versus 50) means that you get a couple of stops more depth of field. D100 + 60mm. Manual. f29 (equivalent) 1/125th. ISO 200. White balance - AUTO. YS30 on FULL.

increased by 1.5 times. For example, a 20mm becomes a 30mm and a 105mm becomes a 160mm. While this does not render lenses obsolete it does

change their characteristics.

The only dramatic transformation is the 16mm fisheye, because so much of its huge coverage is in the corners

of the image, which are outside the CCD. The lens is still wide, but more like 100 degrees than 180. However, the lens also loses much of its fisheye distortion and even in the square sided pool it can be hard spot it is not rectilinear. My 17-35mm becomes a wide/standard zoom of 25-53mm, but with fantastic close focus. My 60mm macro lens is now a 90mm capable of a bit over 1:1. Excellent!

Interestingly, Nikon have just announced a 12-24mm lens, specifically designed for the D1 and D100 cameras that is the equivalent of an 18-36mm. I have not tried this lens, but it will be a serious investment in the system for anyone who buys it, since the lens is not fully compatible with 35mm SLRs.

On a positive note the smaller CCD size actually means that you get better optical quality from your lenses because the CCD uses only the best glass in the centre of the optic, thus reducing vignetting and chromatic aberration and increasing corner sharpness.

TTL Troubles and Flashy Thinking

The D100 has a built in flash, which is not particularly helpful in the housing. Furthermore, the D100 (and D1 series) are not capable of traditional Nikon TTL flash metering. Therefore, they will not TTL with traditional Nikon compatible underwater flashes. Traditional TTL flash metering monitors the light from the flash reflecting off the film while the shutter is open and quenches the gun once enough light has been supplied. CCDs are not as reflective as film so this doesn't



weed+sun.jpg - I am pleased with how the D100 handles light rays, which is something that other digital cameras have struggled with. I imagine much of this different comes from the better optics available on the F mount. D100 + 16mm. Subal D10. No flash. Aperture priority. f6.3 1/320th. ISO 400. White balance - auto.



kimmerage_uwp.jpg - Domeports and wide angle lenses let digital cameras take decent split levels for the first time. With the narrower lens coverage of the fisheye with the D100 notice how much less distortion there is in this image compared with a 35mm fisheye shot. D100 +

work on the D1 and D100. Most interestingly Fuji have solved this problem with the S2 and can manage traditional Nikon TTL. Nikon digitals cannot!

Nikon's solution is D-TTL. And three new flashguns for us to buy: the SB-28DX, SB-50DX and SB-80DX. D-TTL monitors the light from the subject through the lens using pre-flashes in the imperceptible microseconds after the kill button is pressed but before the shutter opens. If the subject's reflectivity changes while the shutter is open the camera cannot adjust and the exposure is wrong. Which is potentially problematic for moving subjects and rear curtain flash.

In addition to housing a D-TTL gun, a number of underwater strobe manufacturer's are busy introducing digital TTL guns for us to consider.

But at this stage, I would strongly advise checking how uw digital strobes really deliver "TTL" with your system before parting with the hard earned.

Of course, manual flash works fine. With instant image review it is very easy indeed to either adjust the aperture or the flash power to fine-tune the exposure. (The camera would make a fantastic teaching aid for flash exposure on photo-courses.) However, I don't want to be messing about with manual flash when the whale shark swims by or the pygmy seahorses are mating. TTL is a tool we have come to expect.

The slowest ISO sensitivity of the D100 is equivalent of 200 ISO/ASA. Presumably more light (slower speeds) does not give a significant increase in performance from the CCD? For anyone used to soaking light into Velvia, the 2+

stops are a big difference. At ISO 200 in a reflective pool, using just a single Sea and Sea YS30 on full power, I produced correct exposures at typical shooting distances at f16 with a 17-35mm and an equivalent of f47 with a 60mm macro at 1:1. Flash exposure has a maximum synch speed of 1/180th.

Balancing act

For my money, white balance control is the most attractive reason to take digital cameras underwater. With daylight balanced film if we photograph a white diving slate above the water it is white. As we go down the water column it will photograph bluer and bluer. This is caused by the change in the light spectrum illuminating the slate (the slate doesn't change colour!). When we go underwater we see more colours than our film can record. Our brain knows the slate is white and recalibrates the colour spectrum accordingly, restoring some of the real colour. In other words, our brain is controlling the white balance of the image. In a similar way a digital camera can control the colour spectrum that the CCD senses and give us white light away from the surface.

The D100 has 7 standard white balance settings, but unsurprisingly there isn't one for "coral reef at 5 metres". However, the camera does have a user-controlled setting, which can be tuned to the in situ light spectrum by calibrating the camera with a grey card. Once you have learned the safe route through the Nikon menu maze, this is very simple.

This doesn't mean you can swim to any depth, whip out the

grey card and have daylight on tap. Colour correction filters will still be required on the lens to get the spectrum into the ballpark. Then the white balance correction can fine-tune this rough calibration back to daylight. In the pool, under tungsten lighting this system works very well. It is one of my main projects for this year to get this working in the sea. And I will report on my progress in UWP.

One of the D100's best features for underwater photography is that it offers white balance bracketing. When switched on this means the camera takes extra images either side (in colour spectrum terms) of the calibrated white balance. But the camera is smarter still, because you only have to press the shutter once and the camera will calculate all three output files from that single exposure!

Verdict

The six million pixel, sorry, dollar question remains: does the D100 produce large enough files to be a replacement for film? Has the future arrived? Well the answer to this question depends on what you want to use your images for. For on screen viewing, projection and home printing - yes. For large reproduction in books and fine-art A3 prints - not quite. For magazine publishing - mostly. But the final decision for magazine image use will be the art editors (who always seem to want 50Mb scans to use as thumbnails!).

In two current UK diving magazines I counted up the underwater images used in features and less

than 5% were equal to or above the D100 output at 300dpi. So in theory you could take 95% of the magazine's images with this camera! But will the art editors let you?

The D100 is a fantastic camera for underwater photography and can simply do things that film cannot. It can take several hundred pictures on a dive, it can let shoot the colours your eyes see, you can alter film speed and shoot is close to darkness, and you can check your results as you go along. But the D100 is not a replacement for 35mm because the final image is still no match for a slide. It is best considered on its strengths not its weaknesses. At this stage the D100 is not a replacement for film, it should be thought of as an alternative or better still companion. A camera which has a completely different set of skills. The future hasn't arrived with the D100, but it is firmly in sight.

Alexander Mustard

**Further reading on the D100 available as eBooks:
Thom Hogan's Complete Guide to the Nikon D100.**

<http://www.bythom.com/d100guide.htm>

Cardinal and Peterson's The D100 and D1 Generation Update.

<http://www.moose395.net>



Strength in Depth



No single manufacturer offers the perfect package when it comes to top of the range equipment.

That's why we, Ocean Optics in the UK, Seacruise in France and Underwater.dk in Scandinavia, looked at all of the manufacturers and chose the best from each.

The result is unsurpassed quality and performance supplied by knowledgeable dealers who use exactly what they sell.

France

Sea-cruise

30 Avenue Edouard Grinda
06200 Nice
tel 33 (0) 493 21 94 64
fax 33 (0) 493 21 29 56
info@sea-cruise.net
www.sea-cruise.net

Scandinavia

underwater.dk

Bjornemosen 79
DK-5260 Odense S
Denmark
Tel 4566194775
Mobile 4540507375
info@underwater.dk
www.underwater.dk

United Kingdom

Ocean Optics

13 Northumberland Avenue
London WC2N 5AQ
Tel 44 (0)20 7930 8408
Fax 44 (0)20 7839 6148
optics@oceanoptics.co.uk
www.oceanoptics.co.uk

Filter fulfilment

by Peter Rowlands

In my review of the Nikon Coolpix 5000 and Subal CP5 housing (UwP8 Aug/Sept 02) I was praising the ability of the “manual white balance” facility. This is a feature which video cameramen have benefited from for a long time but it was not until the advent of digital still cameras that this feature became available to stills photographers.

Conventional (film) still images can/could be improved by adding colour filters to reduce the strong blue/cyan cast of clear water and, if the depth of water and strength of filter are chosen correctly, the results can be very impressive but what a conventional camera does not have is any way of adjusting colours “in” the camera. It merely records the light being presented to it.

Digital still cameras, on the other hand, have electronic circuits which automatically try to get the white balance correct. However, they are not designed to compensate for the blue/cyan casts as well as they are for the reds (much more common in land photography) and what I found with the Coolpix 5000 was that the manual white balance was good up to a certain point/depth and then it just seemed to panic and add huge amounts of red, which proved far too strong. There was no subtle increase after a certain point.

I have been shooting video underwater for many years and I always use a URPro filter in front of the lens when shooting



Believe it or not, this shot was taken at 18 metres with a URPro filter held on with tape between the Nikon Coolpix 5000 and the EC68 wide angle lens. I'm still considering a more elegant way to place the filter!

in blue water. These are American-made filters with a strong red cast (and some other colour added which they keep

secret and have patented). They also produce another filter for green water. The combination of the URPro filter and the video

cameras' capability to adjust the white balance has produced beautiful, colourful shots without the need to add any extra light.

Bearing this in mind I was keen to apply the same principle to my digital stills photography (video cameras are, after all, digital still cameras which happen to take 25 shots per second) so when I was in Dominica recently I put the URPro filter to the test with a Nikon Coolpix 5000 in a Subal CP5 housing as well as an Olympus C40 in their PT-012 housing.

Digital cameras are changing the way we take images underwater and, to a certain extent, they are rewriting the rule books. They are capable of taking much better shots than conventional still cameras although, to achieve the equivalent resolution and rapid response, you will have to dent your bank balance. The reason they are so groundbreaking is that they have the ability to 'adjust the white balance'. This only really applies to available light photography but this is/was where conventional photography was such a poor performer.

Digital still cameras are not, unfortunately, perfect and their white balancing capability is limited unless you buy a digital SLR. Adding a URPro filter will give better colour down to as much as 60 feet/20 metres but, the biggest benefit is that you will not have to manually white balance each time. This involves going into menus, scrolling down and then performing the white balance. That isn't too much bother if you stay at the same depth but go deeper or shallower and you will have to white balance again.



(Above) Available light shot taken with an Olympus C40 set to auto white balance

(Below) The same set up as above but with a URPro CY filter screwed into the lens filter thread



With a filter such as the URPro, what you are doing is helping the auto white balance do its job and that means you can let the camera do the adjusting (and you see the effect on the LCD screen before you take the shot). The result is an amazing but simple combination which will improve the quality of your

available light shots beyond all recognition.

So, I hear you think, "What are the disadvantages?" and it is true - the combination is not perfect.

Firstly, any colour correcting filter will reduce the amount of light reaching the 'film' sensor/chip. I reckon the



(Top)
Available light shot shows that the auto white balance is doing a creditable job and giving better contrast than a conventional film camera would not have been able to achieve.



(Centre)
The same subject lit with the built-in flash has added colour to the stem but as the light from the flash falls off the cyan cast takes over.



(Bottom)
Using the URPro CY filter produces a much more natural image as it compensates for the cyan cast over the whole frame regardless of the camera to subject distance.

All shots taken with a housed Olympus C40 with auto white balance

URPro reduces the light by just over one stop. This will mean a wider aperture or slower shutter speed. That reduction is not a big problem in shallower water but I found I had to change the 'film speed' to 400 to achieve sharper results. This produces shots with slightly more grain ('noise' in digital-speak) but, to be honest, I am a fan of this slight grain as I think it adds more atmosphere.

The second limitation is that the strength of filters such as the URPro mean that the cameras electronics can't achieve a suitable white balance in shallower water around 10 feet/3 metres or less and the results will be too "colourful". The solution is simple - just take off the URPro and let the camera do the white balancing - so there is really only one slight downside,

Using any additional light, either from the models torch or an external strobe will result in the colour being too red so the filter should only be used with available light. To balance the colour in this shot a blue filter on the torch would have helped.

the reduction in light levels.

As far as I'm concerned, that slight reduction in light level is well worth putting up with and I, for one, will never travel without a URPro filter again. I'll even go further than that and say that the combination of a digital stills camera and a URPro filter will change the quality of available light images from now on.

Sceptical readers may think I was given my URPro filters in return for free publicity but I have been using them for many years and I have bought them all. So there.

Peter Rowlands
peter@uwpmag.co.uk



**UR Pro filters are available
from Ocean Optics, London
www.oceanoptics.co.uk**

The System That Fits in Your Pocket. Not empties it.



Digital photography is a breakthrough for underwater snapshooters.

With user friendly automatic features not found on underwater film cameras like autofocus and autoexposure, they are incredibly easy to shoot. LCD monitor screens let you see the image as it really is without the parallax problems associated with budget underwater cameras. Zoom optics that focus down to a few centimetres let you dispense with the hassles and costs of additional supplementary lenses. Instant playback helps you learn as you go and you'll never even have to pay for another roll of film!

Now you can choose from no fewer than 13 different Olympus digital cameras to take underwater.

You can be up and running with a camera and housing for under £410.

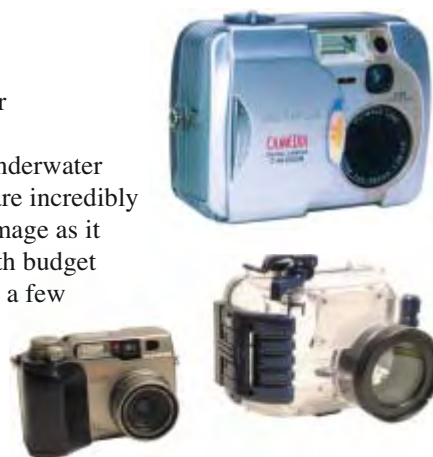

The future of underwater imaging is here. Where it's always been. At Ocean Optics.

Ocean Optics

13 Northumberland Avenue, London WC2N 5AQ
Tel 0207 930 8408 Fax 0207 839 6148

<http://www.oceanoptics.co.uk>

Macro Multi arm

These lightweight strobe arms are very strong and virtually unbreakable yet they can place your strobe in almost any position you want.

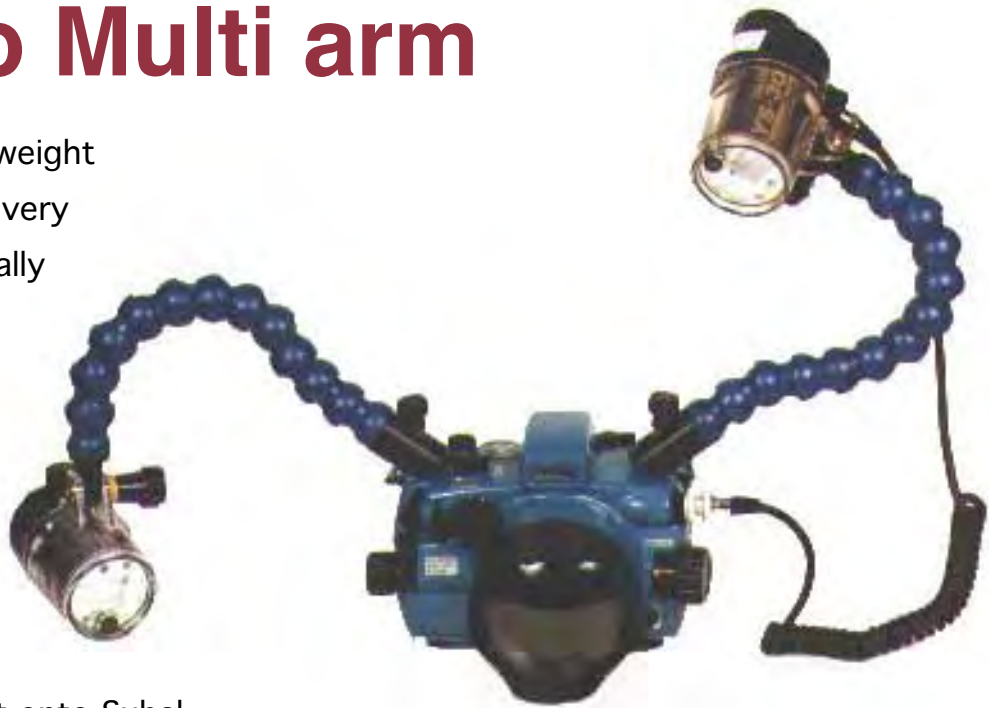

They mount onto Subal housings and take Sea & Sea strobes.

The mountings are anodised aluminium and the base can be easily removed from the housing for hand held shots.

The Macro Multi arm provides incredible versatility at a fraction of the price of other strobe arms.



The Macro Multi arm costs just

£82.25 each inc VAT (plus £2.75 UK postage)

Total £85. Buy two and save £10! (Total £160)

Buy yours today with a UK cheque (payable to PR Productions).

Send it to 13 Langley Avenue, Surbiton, Surrey KT6 6QN.

To order by phone, ring Peter Rowlands 00 44 (0)208 399 5709

or e mail peter@uwpmag.co.uk

Flash of Inspiration

by Mark Webster



It is an old adage that good things often come in small packages, but in underwater photography we sometimes find it difficult to initially accept the principal that a small item of equipment is the equal of a larger one. A good example of this is the way compact housings and small AF cameras have transformed underwater photography over the last ten years or so. Many of us, myself included, resisted change initially firmly believing that our trusty F3's and F2's with large action finders, heavy motor drives and even heavier housings had to be superior, until we tried the minimalist approach and saw the light!

Now that I am a true believer in the 'small is beautiful' maxim I was delighted to be offered the chance to test the latest flash offering from Inon by Steve Warren at Ocean Optics. Steve is of course adept at detecting the weakness in any underwater photographer's resistance to new equipment and was quick to pounce at my mention of "problems with my

Inon Z-220 - The flash head is small and light and has a complex specification which is controlled by two function switches on the rear. The two flash tubes are configured in a 'T' shape to achieve an even coverage over the quoted 100°. A shutter initiated focus light and laser aiming light aid flash positioning and focussing in dim conditions.

The Z-220 is suitable for general and wide angle photography. The flash head weighs only 85gms in water and so is suitable for a variety of light weight arm systems. Nikon F90X, Subal housing, 18-35mm zoom at 18mm, Inon Z-220 and YS30, Elitechrome EBX, f8 @ 1/60th.



old YS120", knowing full well what the probable outcome will be. So, not long after this conversation I found myself on the way to Bonaire with a pair of Inon Z-220's or "T" flashes as

christened by Andrew Bell at Ocean Optics. This epithet is derived from the configuration of the two flash tubes behind the dome of the gun which are arranged this way to achieve an



Snappers at Salt Pier - using a 18-35mm zoom lens with a strong diopter allows you to get very close to subjects if they will permit it. At ranges of 12-30cm I found that the quality of the light was quite warm, although this will be largely dictated by your choice of film stock. Nikon F90X, Subal housing, 18-35mm zoom at about 28mm, two Inon Z-220's, Elitechrome EBX, f11 @ 1/60th.

even 100° coverage, a feature I was keen to evaluate.

The first thing which strikes you is the size and weight of the flash heads. They are barely bigger than a YS30 and weigh very little more, so two of them occupied very little space in my carry on baggage and therefore required almost no defensive transfer of items to pockets in the trusty photographer's vest at the check in. Round one to the 'T' flash, but could these diminutive objects be the equal of my larger guns as indicated by the guide number - f8-11 @ 1m U/W?

Once I started to investigate these little beasts I realised that they are exceptionally well specified. The flash is designed for use with both digital and film cameras and provides connection for both a



Hilma Hooker - wreck photography really demands super wide angle lenses and my favourite is the 16mm fish eye. Using a pair of Z-220's produced good results and I found that when the composition was suitable the TTL exposures were very accurate. Nikon F90X, Subal housing, 16mm fish eye, two Inon Z-220's, Elitechrome EBX, f8 @ 1/30th.

standard (Sea & Sea) synchronisation cord and a fibre optic cord which connects to the slave sensor on the base of the unit. It is also equipped with a focussing light and a laser aiming light, both of which are activated by touching the shutter - they extinguish after several seconds or after an exposure is made. The flash offers TTL function for both Nikon and Canon cameras and the manual power output has no less than eleven settings expressed in half stop increments - this feature is aimed mostly at the digital user. The slave function also operates in a TTL mode, which means that the output will quench in tandem with the key flash. Two densities of diffuser are provided (-0.5 and -3 stops), which will widen the beam spread to 110°, and a directional cap is also available for the slave



Man made structures make fascinating backdrops and are often a magnet to marine life. Some of the largest schools of fish to be found in Bonaire make Salt Pier their home - the multiple powers offered by these strobes are ideal for an exposure like this. Nikon F90X, Subal housing, 16mm fish eye, two Inon Z-220's (-1 stop), Elitechrome EBX, f8 @ 1/30th.

sensor. All this is powered by just four AA sized batteries. Quite an impressive list, but the proof of the pudding as they say....

I tried the guns with a choice of three lenses - 60mm macro, 18-35mm zoom and 16mm fish eye - with the flash guns either both cable synchronised to my Subal housing or with one on TTL slave. I was pretty soon satisfied that they worked extremely well with fish portraits and macro subjects with the 60mm. The results indicated that the slave fires reliably and quenches in the TTL mode with the key light, although I also experimented with the individual power settings in slave as well. When I shot subjects approximately 1m away at f11 the strobes would fire at full power, but the majority of the results were well exposed



Scrawled file fish - I made a number of exposures at an estimated 1m to test the quoted guide number of f8-11. Shots taken at f11 would require a full power discharge but the majority were accurately exposed. Nikon F90X, Subal housing, 18-35mm zoom at 35mm, two Inon Z-220's, Elitechrome EBX, f11 @ 1/60th.

which would indicate that the guide number is not too far off the mark. A pool test might prove this conclusively, but for me the more realistic appraisal has to be in the field where you can assess which subjects will absorb light and require a wider aperture and those which don't. The focus lights work well and are more than adequate for focussing with AF in dark holes or at night, although they are a significant draw on the batteries but they can be selected on or off on the main function switch. The laser aiming spot was surprisingly useful and could be easily seen even on bright sand - this comes on each time you touch the shutter button but has a flip cover if you choose not to use it. The cover should be closed once you have positioned the strobe as the laser will



Three banded butterfly fish - the Z-220 coped effortlessly with standard general and close up photography producing accurate TTL exposures over a range of apertures. Nikon F90X, Subal housing, 60mm macro, two Inon Z-220's, Fujichrome Velvia, f8 @ 1/60th.

sometimes show in the final picture when using wide apertures or slow shutter speeds.

However, the acid test for me was how well they would perform with wide angle lenses. Other photographers looked on sceptically when I entered the water with the fish eye lens and these two small strobes, and I must admit I had my own doubts as well! My usual rig for lighting wide angle would be either a YS120 or Isotecnic 33TTL paired with a YS50 or YS30 for fill lighting and it felt strange to find my system feeling so light and manoeuvrable in the water. The results were a pleasant surprise and the coverage was easily the equal of my usual rig. I tend to work pretty close to my main subject and strive for a balanced light exposure in most cases, so the power output was more than adequate. I took some shots at close range looking towards the sun using apertures of f16 and f11 and the guns once again produced more than enough power. The TTL worked well in wide angle when the composition was ideal (i.e. with the main subject dominating the centre of the frame) whilst for others I utilised the multiple

power settings to balance the light using those old manual exposure techniques! Using the 18-35mm zoom was equally successful (these are such a flexible lens and my 20mm hardly gets a look in these days) and TTL worked very reliably at the longer end of the range. Both flash guns were mounted on light weight 'bendy' arms.

So is there a down side to these flash guns? I have to admit that my initial scepticism for these small units was quickly dispelled and I was delighted with the experience. However, I did find that alkaline batteries soon lost their edge and the recycle time exceeded the quoted 3 seconds if the guns fired at full power. If you use the focus light for each shot as well then you will not get more than a couple of rolls from a set of alkalines. Changing to NiMH rechargeable batteries made a huge difference and recycling was easily within the 1.5 seconds quoted (lithium batteries are apparently not suitable). I also found that although the slave sensor is designed to be omni-directional you still have to make sure that it can 'see' the key light to avoid failure. Using the slave

directional cap would probably improve this, but was not available to me for the test. The quoted colour temperature of these guns is 5500°K which is great for macro, but in fact I found the light to be quite warm when shooting close up with the wide angle lenses and comparing the results to my other flash guns. I found this to be really only noticeable when I was shooting within 12-30cm in wide angle, but this of course can be a benefit to some subjects and will also depend on your choice of film (mine was Velvia for close ups and Elitechrome EBX for wide angle).

So if you are entering the market or looking for a change then the Z-220 is certainly worth a long look. For me the additional attraction is that they are compatible with digital cameras as well which, although I am still promoting my usual Luddite approach to this new technology, is going to catch up with me eventually!

Mark Webster

www.photec.co.uk

Ring of Bright Water

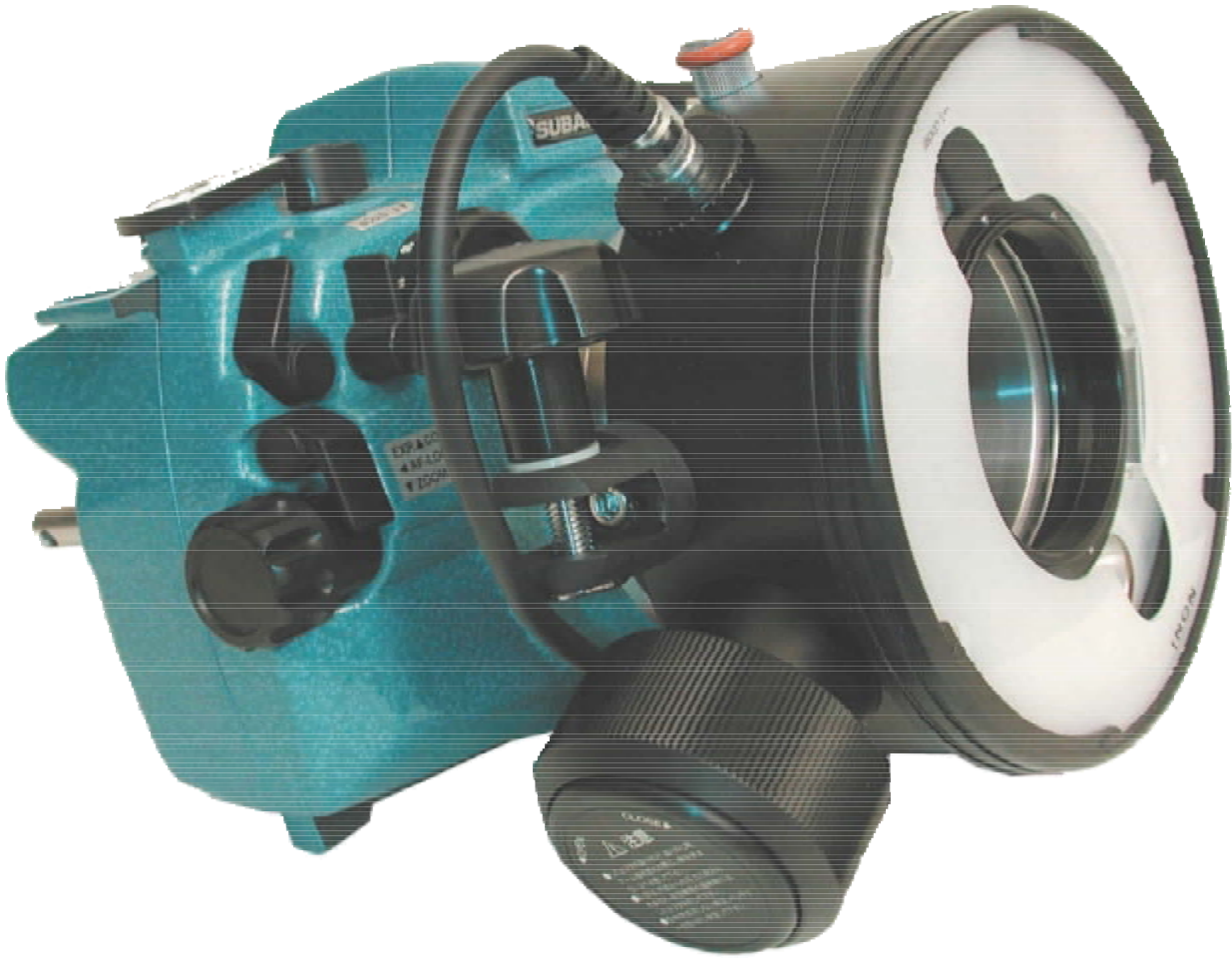

Inon's Quad Flash is one of the most innovative tools ever made available to underwater photographers. The four reflectors provide shadowless lighting with an ethereal quality all of its own. The compact size is less intrusive than conventional strobes and makes animals much more approachable.

The Quad is packed with useful features such as an automatically activated modeling light to assist autofocus and Nikon compatible TTL. To get creative there are three manual powers and a built in shade lets you block off two of the reflectors.

Available with ports to suit both Subal and Sea and Sea SLR housings. Quad from £995.00. Ports from £299.00. For a full review by award winning photographer, author and underwater photography coach Mark Webster see UwP Issue 2 at <http://www.uwpmag.co.uk>

Ocean Optics

13 Northumberland Ave, London WC2N 5AQ
Tel 020 7930 8408 Fax 020 7839 6148
<http://www.oceanoptics.co.uk>

Why St. Vincent?

by **Deb Fugitt**

The best underwater camera equipment in the world doesn't create great photos, photographers do! Of course, it helps the photographer to have excellent underwater camera equipment all in perfect working condition. Even then the photographer must become skilled in their use. What else?

One needs clear water, good ambient light, just the right amount of current, film or storage, powerful batteries, plenty of air in the tank, the usual diving accoutrements plus a lot of patience.

Many times I've found myself somewhere in the world swimming around a dive site with all these necessities miraculously in order searching for subjects and scenes to create fascinating and colorful images and wished I was back diving in St. Vincent where unusual and colorful creatures and backgrounds are so numerous I have to choose, rather than search, for interesting compositions.

What Keeps Me Coming Back?

Since 1988 I've focused (pun intended) my dive trips on searching out the newest dive destinations. I wrote the first articles on the Lembeh Strait's KBR, sailed on one of the first cruises into the Banda Sea, created a web site for a Raja Ampat (Irian Jaya, Indonesia) eco-resort before the scientists began to survey the area. Nevertheless, I return every year to St. Vincent, the only Caribbean destination I visit, for a macro "fix". For me, the macro subject material there can't be beat. Anywhere.

St. Vincent is not especially well known, except by a handful of pro photographers and some lucky travelers who are becoming aware of its unusual situation. This lush green mountainous island is located in the eastern Caribbean's Windward Islands, only a 20 min. flight west of Barbados, north of Grenada and south of St. Lucia. The island is 18 miles long and 11 miles wide. Even a few kilometers north or south of Anchor Reef, Alternative Bay or Wayne's World we don't

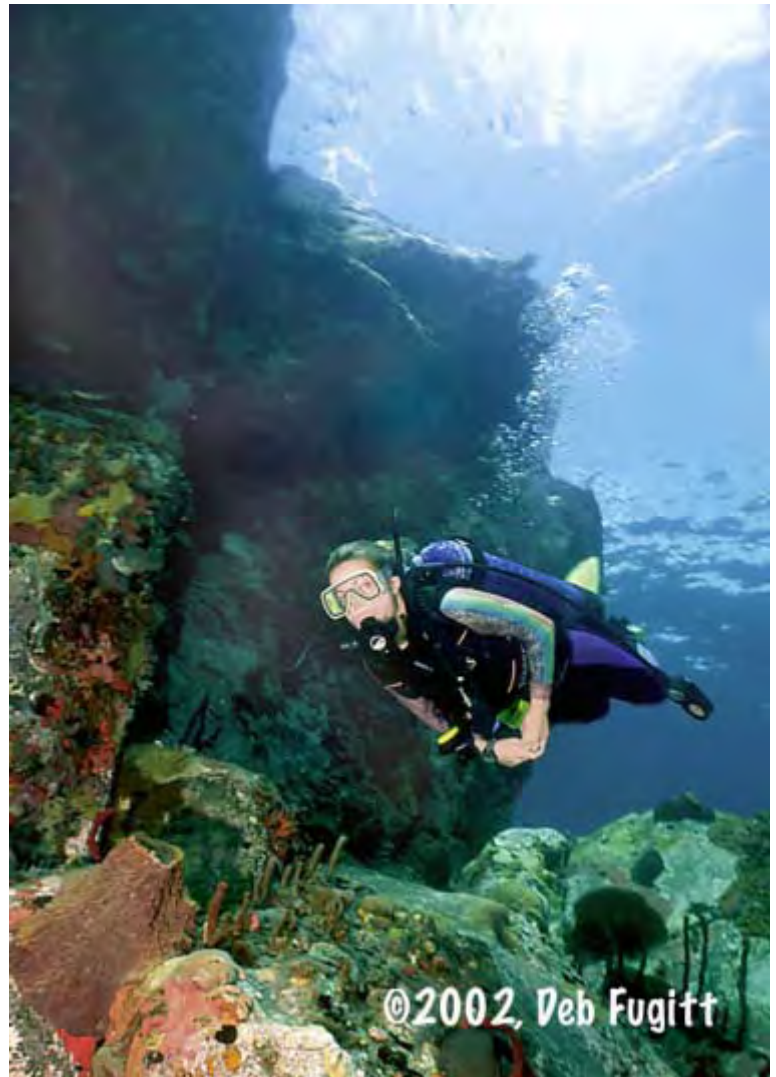

Katie enjoyed the diving at Ocracoke Point, one of our favorite sites with large boulders strewn about the mooring area. Nikonos V & 15mm lens, YS300 and YS120 strobes on manual, full and 1/2 power. Velvia, 1/60th @ f5.6.

find this incredible density of marine life or array of vivid colors. It's a safe and easy exotic dive destination sure to please very experienced divers or beginners alike.

Any conversation on St. Vincent's diving quickly turns into a list of odd creatures. I've been visiting each year for over 20 years and on each visit, am still surprised to find creatures I've never seen before. Our guests' photo contest entries have been suspected of being digitally-created composite images because "Those colors and creatures don't occur in nature." I am writing to say "But, they do!"

I am most surely biased about this destination. After years of visiting on my own and with friends, I began organizing limited participation photo/dive tours to the island in 1996 so that I would have a purpose to spend 6 or 7 weeks on the island each year.



*This 20cm long Tassled Nudibranch, *Bornella calcarata*, found at night on Harbor South South would be a prize anywhere. Nikon F4s in Nexus housing, 60mm, YS300 and YS120 strobes on TTL, Velvia. Manual mode, 1/60th @ f16.*

What IS that?

Anchor Reef is a large and beautiful reef. Like most of our chosen sites for the photo groups, it has diverse habitats for critters. Sand, boulders, sponge gardens, black coral forest, swim throughs, divers take their choice.

One morning our group split up, some following Sarah to find the yellow, black and green frogfishes in the shallow rocky reef; Wayne escorting a couple down to photograph the Bullseye Lobster in the sponge garden just above the black coral wall; Tony off looking for squid on the sandy slope amongst the soft corals; and the others on their own. Everyone is keen to see seahorses. They are plentiful and as a rule, very well



Typical St. Vincent deep reef area. Sponges are plentiful. Nikonos V & 15mm lens, 2 YS300 strobes on manual, full power. Velvia, 1/30th @ f4.



*Sailfin Blenny, *Emblemaria pandionis*. Left – female, right – male. Notice the blurred fin on the male due to its movement. You must have a good eye to spot these tiny wonders unless they are displaying their tall dorsal fins. Nikon F4s in Nexus housing, 105mm, YS300 and YS120 strobes on TTL, Velvia. Manual mode, 1/60th @ f8.*

camouflaged amongst the sponges or in the sea grass, so I decided to scour the shallow sandy rubble area for new seahorses. Success! I found two, but could not find another diver.

As we enjoyed the beautiful scenery during our surface interval, the group chatted about their finds and decided to do a second dive here with offers to share the finds from the previous

dive. I offered to lead Kelly and Barb to my seahorses. As we swam across the featureless sandy bottom and spotted the first seahorse, I heard a squeak! Wow! Good eyes Kelly! That seahorse is tiny and still distant. More squeaks - loud squeaks! Kelly had found one of my favorite creatures of the entire trip. The seahorses were forgotten.

The Flamboyant Octopus

We called Kelly's octopus the "Flamboyant Octopus" due to its wonderfully hued arms, eyes and fascinating textures. Shades of green, magenta and tan covered its arms which were edged with dark brown stripes and white suckers. A dark brown stripe blazed across its eyes which were accentuated with orange and white highlights and for a chic finish, a siphon in a bold golden color. Somehow I feel as if I am writing this for a fashion magazine!

The Brown-Stripe (its common name) octopus, *octopus burryi*, lives in a hole in the sandy sea floor and is out during the day. The lens of choice for this octopus was a 60mm as it allowed us nearer the octopus, which, with patience, could be approached quite closely. The 60mm produced more brilliant colors due to the smaller amount of water between the camera and subject than the 105mm. (I can do the entire trip with a 105mm and not be disappointed.)

We find octopus here, day and night. During our last trip we photographed the Brown-Stripe, White-Spotted (*octopus macropus*), Common (*octopus vulgaris*), Caribbean Reef (*octopus briareus*), Two-Spot (*octopus filusus*), Atlantic Longarm (*octopus defilippi*) and Pygmy (*octopus joubini*) octopi. Squadrons of squid are commonplace. In the summer months of July and August, we often find them mating and placing their eggs in the reef.

Muck diving is extremely rewarding on most of St. V's dive sites. For our photo trips, we use the moorings so as not to disturb the muck creatures. Our



The "Flamboyant Octopus". We renamed this Brown-lined Octopus, Octopus Burryi, because of its unbelievable colors. For some reason, creatures are more colorful in St. Vincent than elsewhere in the Caribbean. A daytime photo, 9 meters, at Anchor Reef. Nikon F4s in Nexus housing, 60mm, YS300 and YS120 strobes on TTL, Velvia. Manual mode, 1/60th @ f11.

group commands the entire boat. We allow divers to enter and exit the water to fix equipment problems and change film, batteries or lenses. Our groups take advantage of it to shoot more than one roll of film per dive. Normally this is a "good thing", unless you find an interesting and skittish subject beneath the boat.

One morning I slipped into the water, the first one out of the boat, and watched as a flounder scooted across the bottom and oozed into a tiny hole! A Longarm Octopus' (a.k.a. "flounder's") home was beneath our boat's dive platform. This octopus is similar to the mimic

octopus from the Indo/Pacific and I would love to watch it for an extended period. Sadly, others in the group only saw the octopus' head peeking out of its hole. It was too timid to stay out while divers were splashing in the water just above.

Eels, Worms, Sponges, Brittle Stars and Colors

I mention this odd quartet of creatures and color because they are included in the comments I hear from experienced divers on their first day in St. Vincent. Without exception, these divers remark that there are more eel species and eel quantities than



Bullseye Lobster, Enoplometopus antellensis.
 Taken at night at 22 meters on Anchor Reef. This rare lobster, common in St. Vincent, is one of my favorites. The target pattern on each side of its carapace is visible in this photo. I caught it in the midst of dinner, notice the crabmeat in its claws. Nikon F4s in Nexus housing, 60mm, YS300 and YS120 strobes on TTL, Velvia. Manual mode, 1/60th @ f11.

any destination they've dived. The same applies to the sponges, worms and brittle stars which are scattered like confetti all over the reefs. Many remark that the same species of creatures are more colorful in St. V than elsewhere..

Some of the prettiest images in my portfolio are still life images of the sponges, worms and brittle stars from St. Vincent. The colors are magnificent! Collections of several different species of Split Crown, Colonial Feather Duster and Christmas Tree worms live side by side in dense clumps. It's especially interesting to set up a shot with a nudibranch, blenny or eel amongst the "posies".

Frogfish

Like seahorses, frogfish are always a favorite find. The vast majority of frogfish are "*Antennarias muliocellatus*", the Longlure Frogfish or the Ocellated Frogfish, (skip the *multi*). Their color variations are remarkable. We find them in shades of red, orange, yellow, brown, gray, black, white, coral and green somewhere between 3 and 30 meters. Frogfish like to stay in the same area for months if they are not harassed. Once they get anxious, they become most un-photogenic, but we chose to dive the same site multiple times and all of us managed to catch several frogfish in great positions for photos.

I had never seen any colored Striated Frogfish, *Antennarius striatus*, besides the usual black and patterned brown until last summer. I certainly did not expect pink! In the sand at 17 meters in Alternative Bay the frogfish's color blended exactly with the nearby sponge, a convenient stop on the way to the boat from visiting the Shortnose Batfish at 30 meters. I'm withholding my pink froggie photo so as not to outdo Peter Rowlands' Dominica froggie in the next issue. (*Very gracious of you, Deb! Ed*)

Crabs, Shrimp and Lobsters

The "rare" Magnificent Sea Urchin, *Astropyga magnifica*, "prefers deep water habitats, rarely within depth range of scuba" according to my Reef Creature Identification guide. Hundreds of these urchins gathered in the sea grass beds at 10 meters depth. These beautiful orange and white urchins' segments are divided by rows of iridescent blue lines, making them one of the most beautiful urchins in the world. On their long spines, tiny purple and white shrimp danced away from our photographers, whom I could hear growling with frustration as they tried to get a clear, in focus, shot of the tiny crustaceans.

While sea urchins and sea cucumbers may not be the most exciting or difficult subjects, their undersides and spines regularly host small shrimp or crabs. In St. Vincent we commonly find pea crabs associated with Red Heart Urchins, Squat Urchin Shrimp with West Indian Sea Eggs or Variegated Urchins, Bumblebee Shrimp with any of the sea cucumbers, Red Snapping Shrimp with the Corkscrew Anemones and of course, the Basket Star, Sun Anemone and Wire Coral Shrimp with

their named hosts.

I've had requests to do 2 night dives every night from people in our groups. Unordinary lobsters, such as the Bullseye, Red Banded and Copper, inhabit our favorite night diving sites as do a considerable number of crab species.

Different species of decorator crabs are quite creative and numerous. So far, we haven't had any divers drown from laughter at their first glimpse of the Furcate Spider Crab. This crab, fondly known to us as the "Anemone Butt Crab", has elicited laughter from nearly everyone on a night dive at one time or another. I can't begin to list the names of all the spider, swimmer, decorator, box, hairy, mud, hermit, clinging or sponge crabs regularly found on St. Vincent's reefs.

Patience Required

Critter Corner, the recently re-named dive site beside Young Island, is a favorite with photographers. This area was recently declared an island treasure and is now protected as a Marine Life Sanctuary. The site is shallow and featureless with sandy rubble and sea grass areas. Shooting the Sailfin Blennies, Yellow-Face and Blue-Throat Pike Blennies, and Yellow-Head Jawfish there can require a large degree of patience (and may be impossible with framers). While pike blennies can be extremely difficult to find, sailfins are easy to locate, if one keeps an eye on the sand watching for their courtship dance. Every few minutes, the tiny male sailfin comes out of its hole, raises its sail to full height and gyrates wildly, in hopes of attracting a mate. Hah! He attracts photographers too!

Although we sometimes use a mirror to lure these miniscule beasts out of hiding and snap their photo as they attack their own reflection, the mating dance creates a much more appealing image. Patience will also get the pike blenny out with its tall dorsal fin and spaghetti-thin body. With their mouths full of eggs and their unusually brilliant blue and yellow coloration, St. Vincent's jawfish make the photo worth the wait.

This site has not only these small fish (often in abundance), but also frogfish, seahorses, Spotted Snake Eels and a curiously large number of urchin species.

Patience IS a virtue, but one shouldn't focus all attention on getting the shot. Sarah and I nearly had heart attacks as we watched Don inch along,



We searched for these two seahorses every week. When they were found I had 1.5 remaining frames, a 105mm lens and anxious twitchy seahorses. Nikon F4s in Nexus housing, 105mm, YS300 and YS120 strobes on TTL, Velvia. Manual mode, 1/60th @ f5.6.

arms on the sand, closer and closer to a male sailfin. As he moved in for that perfect shot, his forearm touched, moved and mashed the head of a Spotted Snake Eel into the sand. The snake eels are quite vicious looking and could be dangerous. Don was lucky.

When to Go?

The most prolific time for marine life in St. Vincent is July and August. The water is warmer, vegetation is greener, the Flamboyant Trees are in full (and very red) bloom, the crustaceans more numerous and the marine life more active. Visibility varies widely from 15m to 35+ and is not related to the season

Our groups average 3 to 4, 70-80 minute dives per day usually with one shallow dive of 90-120 minutes each day. The warm summer water keeps us comfortable with only a 3mm wetsuit for



Indian Bay, Young Island and Critter Corner with Bequia in the distance. Most hotels are in this area.



*Frogfish, *Antennarius ocellatus*. This frogfish changed colors over a few days time. The photo is the in-between stage. We've noticed other frogfish change color overnight. The yawn is a defensive posture. Nikon F4s in Nexus housing, 60mm, YS300 and YS120 strobes on TTL, Velvia. Manual mode, 1/60th @ f11.*

thermal protection. Hard core photographers should organize or join a like-minded group, otherwise they may dive with other tourists on a different agenda and schedule. The standard schedule for the three local dive shops is 1 or 2 morning dives.

What to bring?

Your macro setup for sure! With housed film cameras I've found the 105mm macro lens most useful and take it on 90% of my dives. The 60mm macro is very good as well. It is great for most of the eels, frogfish, batfish, lobsters, some of the

crabs and reef fish.

There are some wonderful spots for wide angle photography if the visibility is good and you can control the impulse to continue shooting macro. Forests of black corals, walls of golden cup corals, stacks of large boulders, fields of delicate finger corals and areas of sensuous soft corals and fans can be reached from the sites where good macro is also available. If you have room, pack a separate system for wide angle photography and leave it on the boat until you want it.

Film? That depends on your preference, camera and strobes' color temperature. I shoot Velvia for everything. Just bring more film or memory storage than you think you will possibly need. The electricity is 220 volt, 50 cycles with the 3 prong plug. 110v is not always available in the hotels. Odd batteries may not be available. Bring all you need.

The dive shops have rental equipment but no computers. Multi-day, multi-dive trips such as ours require one computer per diver. Clothing is cool and casual. The temperature ranges from 24C (75F) to 30C (86F). A windbreaker is recommended for use on the dive boat.

Deb Fugitt

Deb is a professional photographer, specializing in Internet Marketing for dive and travel related businesses and leads trips to her favorite destinations.

Info on this destination:
www.scubasvg.com

On Deb's trips www.dive-st-vincent-scuba-diving.com

2003 & 2004

St Vincent

Critter Dive & PHOTOGRAPHY Trips

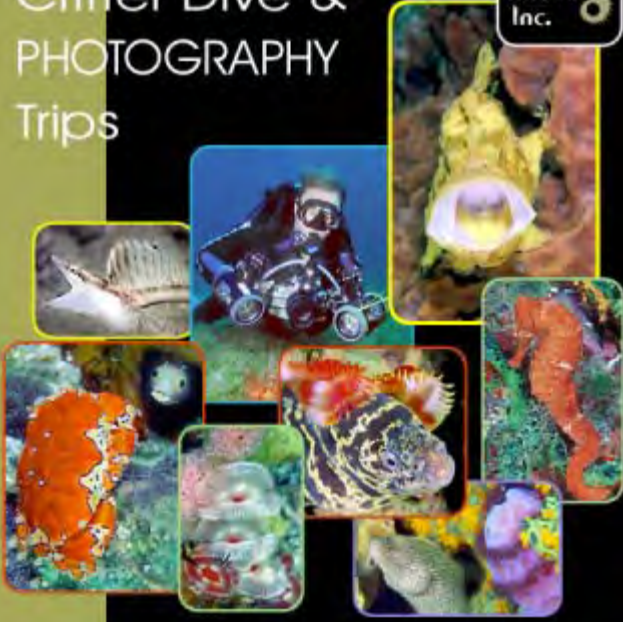

City Seahorse Inc.

Details / Prices / Schedules / Photos:

www.dive-st-vincent-scuba-diving.com

also custom tours arranged for your group

tours@dive-st-vincent-scuba-diving.com

Bill Tewes' Dive St. Vincent

"The Critter Capital of the Caribbean"

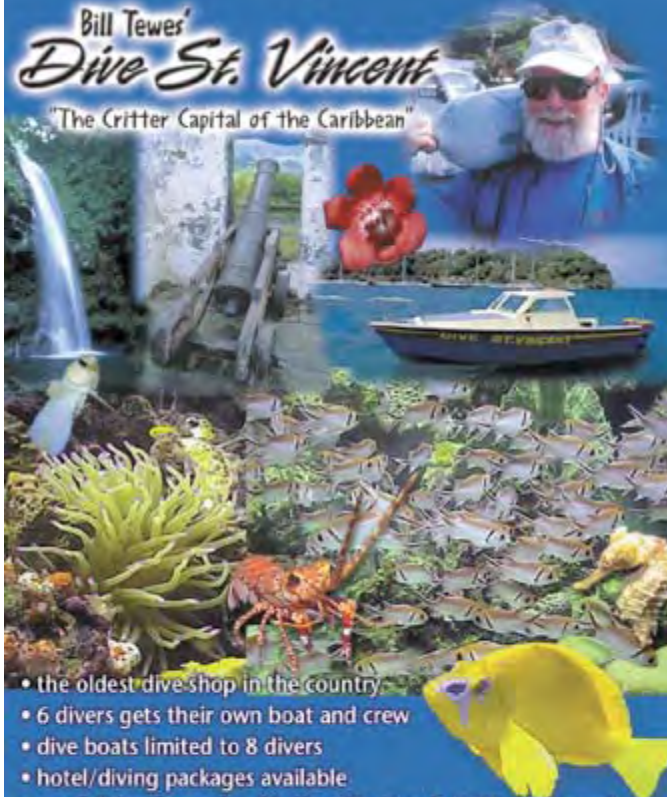

- the oldest dive shop in the country.
- 6 divers gets their own boat and crew
- dive boats limited to 8 divers
- hotel/diving packages available
- specializing in marine life identification & U/W photographers

P.O. Box 864 • St. Vincent, West Indies
 Main Office: 784-457-4928 • Dive Shop: 784-457-4714
 Fax: 784-457-4948 • VHF 16/68
 email: bill2s@DiveStVincent.com • web: www.DiveStVincent.com

Ever wondered, half way through a liveaboard trip, whether your pictures are even coming out?

Well now there's a simple, exciting solution.

Digital cameras are turning underwater photography on its head. For as little as £450.00 you can buy a digital camera and housing. And that could be all you need to take great pictures.

That's because most of what you add on to conventional underwater cameras is built-in with digitals. Without any extra lenses you can zoom in tight on a small skittish fish or get within centimetres of a colourful nudibranch. **Less to prepare, less to maintain and less to spend.**

In fact less is definitely more. Digitals are usually less bulky than conventional underwater cameras and offer more user friendly features. Like the ability to replay all of your images right after the dive (even during it with some systems). It makes learning to use your camera much faster and gives you confidence that your pictures really are coming out.

For more information call Ocean Optics.



Ocean Optics 13 Northumberland Avenue, London WC2N 5AQ

Tel 0207 930 8408 Fax 0207 839 6148

Web site

<http://www.oceanoptics.co.uk>

Cornish Jewels

by Mark Webster

Regular clients on my overseas workshops have become accustomed to my regular references to the joys of diving in British waters. My tack is normally the same - if you can perfect your techniques in the temperate waters of the UK then you should be able to shoot successfully anywhere around the globe. Perhaps a better reason is that there are some superb subjects and scenery which are enough to inspire even the most jaded globe trotter - if not then the colder water is sure to get your attention!

In my continued quest to sing the praises of our waters I thought I would highlight two of the most photographically productive diving sites I am lucky enough to have on my doorstep. Both are submerged reef systems located offshore in the path of strong tides, which in our waters equates to masses of colourful invertebrate life and healthy fish populations. The first is the Manacles reef off the Lizard and the second is the Runnel Stone close to Land's End.

The Manacles:

The land mass of the Lizard peninsula is the most southerly point of the United Kingdom. Its position reaching out into the English Channel has been a major navigational way point as well as a hazard since the earliest



Basking shark - The plankton blooms in late spring early summer reduces the visibility in the water column but is also a magnet to the plankton feeders like the basking shark. To get good pictures of these beasts needs a combination of timing, luck, patience and a good set of lungs to keep up on a snorkel! Nikon F90X, Subal housing, 20mm, Elitechrome EBX, f5.6 @60th.



Jewel anemones - These tiny anemones come in both subtle and vibrant colourways and make fantastic macro subjects. Nikon F801, Subal housing, 60mm macro, Fuji Velvia, f11 @ 1/60th, YS50 and YS30.

days of sail. The granite cliffs, sheltered bays and offshore reefs boast some of the best diving that this area has to offer. One of the most popular of these areas is the infamous Manacles reef which lies on the north eastern side of the peninsula at the edge

of Falmouth Bay. This reef comprises a series of granite peaks and ledges rising sharply from depths of 60-70m to break the surface or lurk just 2m or 3m below the water.

This reef area rates as the most spectacular in Falmouth



Lands End - The Cornish coast is extremely rugged with high granite cliffs tumbling into the sea. This topography continues in many areas underwater which creates spectacular plunging reefs with multitudes of gullies and swim throughs to be explored. Nikon F90X, 28-200mm zoom, Elitechrome EBX, f8 @ 1/60th.

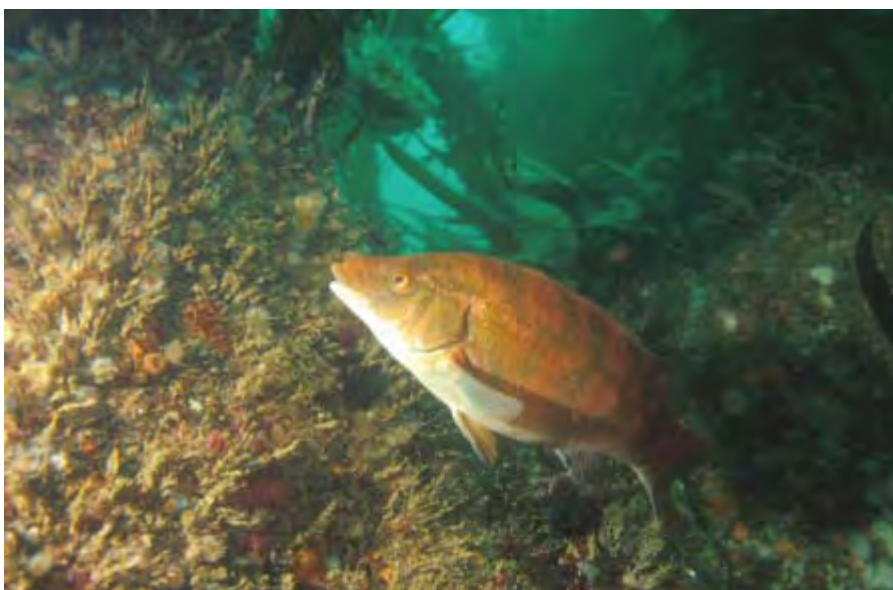

Ballan wrasse - Ballan wrasse are the groupers or coral trouts of temperate reefs. They are very territorial and inquisitive and will make repeated approaches to you if you are patient and stay in one spot for a while. They seem to particularly like games of hide and seek within the kelp which can be a challenging place to remain even in a light surge. Nikon F90X, Subal housing, 18-35mm zoom, Elitechrome EBX, f5.6 @ 1/30th, Isotecnic 33TTL and YS30.

Bay, but must only be dived when the conditions are right. Vicious tides of up to 5 knots are experienced here, and the current continues to run sometimes even during “slack” periods on a

spring tide, and sadly there have been several diving tragedies in the area. The best diving is found on the outer reefs of the Manacles where the rocks are most exposed to the tide and the

density of marine life is often quite staggering. Much of the reef system does not reach the surface, so it is important to go with a boatman who knows the area and tides and can identify the sites. The whole area offers potentially excellent diving and it is well worth trying more than one of the reefs as they all have a different feel and topography.

Perhaps the most spectacular site is Raglans Reef, which is the most seaward of the reefs and looks very impressive on the echo sounder rising sheer from a depth of 50-60m to within 3-4m of the surface. The reef can only be located with a combination of land marks and transits or a GPS fix and an echo sounder. You should plan your dive for slack water and preferably on a neap tide for a long dive. Arriving on location before the tide is slack will enable you to spot the surface disturbance caused by the tidal waters being thrown towards the surface by the obstruction of the reef. This will give a clue to the location of the reef top and you may begin you sweep with the echo sounder upstream of the disturbance. When you are waiting for the tide to stop running there will often be a ‘false slack’ period when the current appears to stop only to restart again with a final surge 10 or 15 minutes later. It is possible to dive at this moment when there is a neap tide, but on a spring it is best to wait for full slack water. If you are an experienced diver then it is possible to start or finish your dive when the tide is running, as the reef will offer shelter on one side. However, your boat man must be experienced and be alert to the possibility of divers being



Gulley with sponges - There are ledges and gullies to be explored throughout the depth range. Each provides an avenue of different sessile life, one might be full of anemones and the next full of sponges and dead men's fingers as in this case. The bright granite sand which collects in the bottom of these reflects both the natural light and your flash to help fill shadows. Nikon F90X, Subal housing, 16mm fish eye, Elitechrome EBX, f5.6 @ 1/30th, YS120 and YS30.



Cuttle fish - Cuttle fish are most common in the mid summer months and you will find them up amongst the kelp canopy or on sandy patches on the reef slope. They have remarkable camouflage skills and can be difficult to spot initially but make willing photographic subjects once found. Nikon F801, Subal housing, 60mm macro, Fuji Velvia, f11 @ 1/60th, YS120 and YS30.

carried away by the tide particularly at the end of a dive. Always carry a surface marker sausage or flag so that your boat can spot you easily on the surface. The other cautionary note for this area is its popularity especially on holiday week ends when there will be a large number of diving boats operating in the area. So be aware of other boat traffic especially when surfacing at the end of a dive away from the reef.

To be certain of locating the

reef when you leave the surface it is best for the boat to anchor to the reef top or to deploy a marker buoy on a grapnel or shot weight. If you miss the narrow reef top then you run the risk of not finding the reef at all or hitting it at a depth far greater than planned. The top 5-8m has a heavy growth of kelp with widely spaced stipes which provides shelter for many marine organisms. This area is best left for exploration until the end of your dive when you are

decompressing or making a safety stop. Just below the kelp line around 8m the rocks are covered with hydroids, masses of brittle stars, endless arrays of jewel anemones and soft corals. The best route to follow is to start on the north east side of the pinnacle where you will find a series of vertical rock faces which are carpeted with sea fans and plumose anemones in a variety of colours. Follow these to your target depth and then begin to swim around the



Rhizostoma jelly fish - The spring plankton bloom attracts swarms of jelly fish, the largest being the Rhizostoma. This year (2002) they were particularly prolific and literally dozens would pass by every few minutes during a dive. Plenty of bracketing will ensure that you do not over expose the reflective white body of these animals. Nikon F90X, Subal housing, 18-35mm zoom, Elitechrome EBX, f5.6 @ 1/30th, Isotecnic 33TTL and YS30.

pinnacle either west or east dependant on which way any current may be flowing. On the reef edge watch out for shoals of bass which like to congregate in eddies created by the current striking the rock faces and feed off the disturbed plankton. As you make your way around towards the south face gradually decreasing your depth you will find that the sheer rock faces change to a series of large ledges and boulders with small sandy patches collected in the hollows. Stop and inspect these as you will often find angler fish, topknot flat fish or dog fish and tope resting here. The decreasing depth will also reveal more reef fish activity with ballan wrasse, goldsinney wrasse and the very bold and inquisitive cuckoo wrasse approaching you to



Lomanotus nudibranch - We have a great variety of colourful nudibranchs in our waters, which are certainly the equal of their tropical cousins, but they tend to be quite small in size. The exception to this is the splendid Lomanotus which may be 4-5cm in length and is found in this iridescent yellow colour or a shade of red or pink. Nikon F90X, 105mm macro, Fuji Velvia, f16 @ 1/125th, Inon Quad flash.

investigate. In the spring there will be clouds of juvenile fish shoaling just below the kelp line often being herded and hunted by marauding groups of pollack some of which reach an impressive size and are very bold.

This is an excellent site for photography, not least due to the range of subjects, but also because of the depth ranges available in one dive - go deep first, then decompress in the shallows looking for macro subjects. The charted position of Raglans Reef is 50.02.63N, 05.02.45W. Slack water is generally found one hour before low water and one hour after high water at Falmouth.

The Runnel Stone

Further west and close to Lands End is the infamous Runnel Stone which is reputed to have wrecked more than 27 ships. The Runnel Stone is in fact an extensive area of reefs and pinnacles which lost its only surface breaking feature to the last vessel to be wrecked on the Stone, the City of Westminster in 1923. The reef is now marked by a buoy within sight of Lands End and the Longships reef lighthouse and is consequently open to Atlantic oceanic conditions. Tides and weather need to be right and even in good weather there is normally a healthy swell to contend with. Local knowledge is essential as the tides are vicious and sometimes unpredictable and the weather can change very quickly. But under the right conditions the Stone is simply stunning.

The topography is immensely rugged, the geology granite and serpentine, which produces a bright yellow heavy sand, and there are no river out falls to upset the visibility. These ingredients are perfect for a dense proliferation of encrusting marine organisms and attracts fish which enjoy the shelter a reef provides, dwell in the sand or prefer the flow of the tide to bring them food. This whole area provides a rich microcosm of reef life in temperate waters

Due to the strong currents at this location only the hardiest of sea weeds are able to take hold and thrive. However, the kelp canopy here extends down to between 5 and 8 metres, less where the reef walls are particularly sheer, and provides shelter for a wide variety of



Pouting - There are several wrecks mingled together on the Runnel Stone, but the most distinctive remains are those of the City of Westminster. Throughout the wreck you will encounter large schools of pouting who are very patient with persistent photographers. Dependant on the time of year you will also find shoaling bass, scad and mullet. Nikon F90X, Subal housing, 18-35mm zoom, Elitechrome EBX, f5.6 @ 1/30th, Isotecnic 33TTL and YS30.

marine life both sedentary and mobile. Sponges abound and the first signs of jewel and daisy anemones can be found in as little as 3 metres of water. Looking up toward the kelp line graceful plumose anemones can be seen extended sifting the current. In amongst them are daisy and dahlia anemones. Where the kelp ends the fields of jewel anemones begin in almost every colour you can imagine from vivid yellows to deep purples. These are interspersed with the stems of hydroids reaching out to feed. Inspect these hydroids closely as more often than not you will find two or three species of nudibranch feeding on them, particularly in late spring when they are reproducing. Remaining space on the rock surface is occupied by masses of feather stars and brittle stars again seemingly coloured by every hue from a painters palette.

Along the wall you will find countless nooks, crannies and ledges which are home to crabs, squat lobsters, blennies, shannies and prawns most of which are both inquisitive and co-operative. The best photographic tool here is a housed SLR with a macro lens, the opportunities are endless. You should keep your eyes open for scorpion fish and the Corkwing wrasse which can be found busy building it's nest early in the summer. Cowries and topshells are common on the kelp holdfasts and there is normally an abundance of spider crabs picking their way amongst the kelp stipes. Look carefully at the stipes as you will often be lucky enough to see more than one pipefish taking advantage of their camouflage. As you go deeper the reef system offers walls, gullies and plateau's which support an astounding wealth of marine life, even playing host to the occasional



Dead men's fingers 1 - Below the kelp line you will find swathes of soft corals known locally as dead men's fingers. They vary in colour from white to yellow and this string orange colour, making an ideal wide angle subject. Nikon F801, Subal housing, 16mm fish eye, Elitechrome EBX, f5.6 @60th, YS120 flash.

sub-tropical visitor such as trigger fish and sun fish. It is common to encounter large shoals of mackerel, bass and pollack which show little fear of divers. In amongst the rocks are the remains of the numerous wrecks, which in some cases are so close or overlapping that it is difficult to tell when you swim from one to another.

One of the best known and the largest is the City of Westminster which now lies on the south side of the Stone. She was on a voyage in October 1923 from Belfast to Rotterdam with a cargo of 2400 tons of maize when she ran into dense banks of fog as she rounded Lands End. In those days the top of the Runnel broke the surface and was marked by a beacon, but this was entirely invisible to the skipper in these conditions. The ship was too close inshore and she hit the stone under full



Kelp stypes - The reefs top out between 4-8m where you will find dense canopies of kelp. Save some film for the end of the dive as the stypes are home to all sorts of macro critters and interesting wide angle compositions are also possible. When the sun is in the picture you will need to meter the scene carefully and allow a little extra exposure for the dark green kelp fronds. Nikon F90X, Subal housing, 18-35mm zoom, Elitechrome EBX, f5.6 @ 1/30th, Isotecnic 33TTL and YS30.

power, so hard that the bows broke off the top 3-5m of the stone complete with the beacon as the hull drove over the reef ripping out her keel. The ship quickly broke her back and disappeared beneath the waves, fortunately without any loss of life. Her remains include the bows and mid ships section in 20-25m whilst her stern lies a little off the main reef in 50-55m and is consequently rarely dived. The ship is well broken open by the pounding of the Atlantic swells here, but there are many recognisable features and if you search in the gulleys on the north face of the reef you will even find the remains of the Runnel Stone beacon knocked so carelessly from its perch all those years

ago.

Other wrecks in the immediate vicinity are the Royal Fleet Auxiliary 'Moorview' (1920), the Febrero (1863), the Lake Grafton (1920), and the Joshua Nicholson all in depths of 15-25m. It is possible to satisfy every diver's taste on the Runnel Stone with more wreckage than you could sensibly cope with and the option and contrast of the adjacent spectacular drop offs and gullies for photographers and marine life observers. The visibility here is generally very good, with 20m not uncommon, although the plankton bloom in late spring/early summer will reduce this but will bring the possibility of an encounter with a massive basking shark or squadrons of huge Rhyzostoma jelly fish.

As mentioned previously this area is very exposed and should only be considered in ideal conditions. What appears to be a calm sea when launching from Penzance can become heavy going and dangerous by the time you round the headland at Lamorna Cove if winds are coming from the South or West. The best period of slack water is one and a half hours before low tide at Penzance, although it is possible to dive on a high water slack during neap tides. Nowhere along this stretch of coast should be dived without the benefit of local knowledge which is best sourced from the local diving clubs or charter boats. The nearest is the Penzance branch of the BSAC which has its clubhouse on the harbour side at Albert pier. At present there is only one daily dive charter boat operating from Penzance, the Son Calou skippered by Bill Bowen of Mounts Bay Diving,



Cuckoo wrasse - The male cuckoo wrasse is perhaps the most colourful fish in UK waters. They are very inquisitive and territorial and will make repeated approaches towards a photographer, particularly when they can see their reflection in a camera port! Nikon F801, Subal housing, 105mm macro, Fuji Velvia, f11 @ 1/60th, YS120 and YS30.

who also operates a compressor on Albert pier.

If you are diving from your own boat then the Runnel Stone is easy to find using land marks and an echo sounder. Position your boat close to the buoy and look towards the shore at Lands End. On the cliff top you will see two cones, the closest one red and one further in shore which is black and white. Line these two up as you steam slowly inshore from the buoy whilst looking north east towards the headland (Ped-men-an-mere) adjacent to the cliff top Minack theatre and the cove of Porth Curno. On the cliff top on the far side of Porth Curno is a white triangular land mark, as this begins to be covered by the headland you will be over the Runnel Stone. Watch your echo sounder as the depth jumps from 35-40m to 5-6m perhaps 150-200m from the buoy (see sketch). The charted position of the stone is 50.1.33N, 5.40.33W.

Runnel Stone Info:

Launching Points:

Penzance - slipway
Lamorna Cove - slipway
Porthgwarra - awkward beach launch for small boats only
Sennen Cove - beach launch

Day Boats:

Son Calou: 01736 - 752135
Cornish Diving: 01326-311265
Undersea Adventures: 01736 333040

Live Aboards:

Mentor Maritime: 01872-862080
MV Maureen: 01803-835449
MV Chalutier: 01392-431841
Dunedin: 01548-842057
McGregor: 01503-263584



Dahlia anemones - There are a wide variety of anemones on both the Manacles and the Runnel Stone which appear in colours to rival those of a tropical reef. Using a focussing torch to check the real colour will help you choose the most striking. . Nikon F801, Subal housing, 60mm macro, Fuji Velvia, f16 @ 1/60th, YS120 and YS30.

Air:

Mounts Bay : 01736-752135
Trevair: 01736: 740647
Undersea Adventures: 01736 333040

More information:

Penzance Tourist Board Tel. 01736 62207
Falmouth Coast Guard Tel. 01326 317575 Fax. 01326 318342
Penzance BSAC: Tel. 01736-69213
Penzance Harbour Master: Tel. 01736 66113
Lamorna Cove Tel. 01736 731734

Manacles Info:

Launching Points:

Falmouth Bay:
Falmouth Watersports Centre - slipway
Maenporth - beach launch
Lizard:
Porthkerris, Porhoustock - beach launch
Mullion - slipway
Poldhu Cove - beach launch

Day Boats:

Porthkerris Diving Centre : 01326-280620
Patrice: 01326-313265
Cornish Diving: 01326-311265
Seaquest: 01326-375544
Gangy Lady: 01326 375458
Dive Action 01326-280719

Live Aboards:

Mentor Maritime: 01872-862080
MV Maureen: 01803-835449
MV Chalutier: 01392-431841
Dunedin: 01548-842057
McGregor: 01503-263584

Air and Nitrox:

Cornish Diving: 01326-311265
Seaways: 01326-375544
Haven Underwater Centre: 01326-250852
Porthkerris Diving Centre : 01326-280620
Dive Action 01326-280719
Dive Kennack: 01326-290533
Franchis Holiday Park: 01326-240301
Cornish Diving Lodge: 01326 290633
Divers Den: 01326 280365

More information:

Falmouth Tourist Board Tel. 01326 312300 Fax 01326 313457
Falmouth Coast Guard Tel. 01326 317575 Fax. 01326 318342

Mark Webster

Mark Webster is the author of 'The Art and Technique of Underwater Photography' (published by Fountain Press) and Diving and Snorkeling Belize (Lonely Planet).

Mark hosts regular workshops both overseas and in the UK.

For further details visit his website at www.photec.co.uk

Sony TRV900 housing system for sale



This housing is self designed and professionally machined from aluminium.

All of the controls are mechanical for reliability yet they are positioned ergonomically for ease of use.

There is an external 5" colour LCD viewfinder which allows you to compose your shots from almost any angle.

The battery pods in the base provide power for the monitor

and for an external light such as an HID.

There are two internal flip filters - colour correction and close up lenses and the camera is secured on a baseplate which holds it within the housing extremely accurately.

There are controls for stop start, zoom, manual focus,

autofocus, white balance, exposure, shutter speed and aperture.

The system comes in a fitted Sealtight case and includes housing, Sony TRV900 camera with two batteries, colour monitor (with spare LCD panel worth £250), 4 x battery packs for lighting and monitor power

The system is for sale complete and cannot be broken up for it is designed to provide the highest quality results from a small neat package.

The system is for sale at £2500 inc VAT and UK postage.

(An overseas buyer would not have to pay 17.5% VAT).



Light & Motion SunRay Pro HID lighting system for sale having seen little use. Includes 5 batteries and a 110/240v charger. All cables and arms included. Price new approx £2200. This

system is for sale at £1150 inc VAT with free shipping within the UK. (An overseas buyer would not have to pay 17.5% VAT)

For further details about these systems please contact Peter Rowlands. Tel 00 44 (0)20 8399 5709 or e mail peter@uwpmag.co.uk

What a Croc

by Kelvin Aitken

Sharks have long been the bad boys of the ocean, having the reputation of being fierce man eaters. On rare occasions this has even been true but they are not the most dangerous marine animal on this planet. Box Jellyfish can kill in a few minutes, inflicting pain so intense that the victim dies of heart failure. Or sea snakes have a venom as deadly as any land snake.

The simple solution to these apparent threats is to just stay out of the water. Take up bull running, rodeo riding or elephant racing because none of those animals will climb out of the sea and kill you.

But not so with a croc. The Salt Water or Estuarine Indo-Pacific Crocodile (*Crocodylus porosus*) is the largest predatory reptile on earth and will climb out of the water to drag you screaming to your watery grave. OK, that sounds a bit over the top but in essence it is true. Crocodiles are amphibious and have taken both swimmers and land lubbers in salt and fresh water environments, sometimes far inland.

However like sharks, crocodiles are far more complex than a simplistic title such as “man eater” can convey. Lets give one a poke and see what makes these majestic predators tick.

Being reptiles, crocodiles are considered to be “cold blooded”. That means that they need the sun and surrounding environment to moderate their



Living just above the salt water line this croc inhabited a river near a popular swimming hole north of Cairns, Queensland Australia. Nikonos V, 15 mm lens, Velvia, f5.6@1/15 manual exposure.

body temperature. That is why they are usually spotted above water resting on river banks or beaches as they use the sun’s radiant energy to raise their core body temperature.

Like turtles their sex at birth is determined by the incubation temperature of the nest, particularly in the first half of the incubation. A variation of half a degree or more above the “ideal” temperature of 31 degrees produces mostly males while a nest with a temperature below 31 degrees Celsius produces mostly females.

Unlike turtles they do not dig a nest in sand but instead create a shallow nest on land in which a number of soft shelled ovoid eggs are laid. A large mound of plant matter is then raked over the eggs providing them with warmth from the resulting heat produced by the rotting vegetation. A female may add to or subtract debris depending on the nest temperature. Some croc species do dig pits but here we will just consider the natural history of the Salt Water (*Crocodylus porosus*) species.

This large adult appeared regularly on a beach at one of the many river mouths in Milne Bay, Papua New Guinea, only a short distance from a village. Their skittish nature makes such images much harder to obtain than some underwater images. Canon EOS3, 70-200 mm L lens, Provia, f16 @ 1/60, manual exposure.



A large adult around 2.5 m long lived for a short time between two river mouths. It was quite possibly evicted from river territory by stronger and/or larger crocs. Milne Bay, Papua New Guinea. Nikon 801S, Aquatica housing, 20 mm lens, Provia, f11 @ 1/60, manual exposure.



The eggs mature over 60-90 days and when ready to hatch the young break open the soft shells from inside using a small sharp protrusion on their snout. At this time they will emit a croaking call which summons the mother to the nest where she will help to free them from the nest mound and take them gently in her mouth and transport them to the nearest water. Unlike turtles, this species of crocodile will care for and protect their young.

Initially the newborn will feed on insects, frogs and small fish but if successful in the wars of life will graduate to large fish and mammals. And that's where we enter the food chain.

My first experience photographing crocodiles was in northern Australia where I photographed a 6' female in a freshwater river, just above the tidal mark of the nearby ocean. One thing that I had gleaned from researchers and rangers was that crocs are territorial where generally the largest

animal wins. So, when photographing crocodiles only chose those that are smaller than yourself. Other divers have had experiences photographing small crocs successfully because they are "programmed" to survive by not attacking a larger "competitor", namely the diver.

The fact that I was only about 2 inches longer than my first subject may be why I felt nervous the entire time. Or maybe it was just the fact that someone had been attacked a week before nearby.

When diving with sharks or other marine predators an experienced diver can pick up on the body language to determine if remaining in the area is safe. Threat displays, particularly among Grey Reef Sharks (*Carcharhinus amblyrhynchos*), have been well documented and are obvious as an indicator to an individual shark's temperament. Great Whites, Tiger Sharks and Grey Nurse (*Carcharias taurus*) as well as many other species

also may charge, twitch or “jaw chomp” to indicate their mood. Crocodiles on the other hand give absolutely no indication as to their mood. They may be asleep, afraid, nervous, or ready to launch an attack with the intention of either driving you off or eating you. There is no way of knowing what is going through their walnut-sized brain until they act with blinding speed. That is what makes photographing crocodiles underwater so fraught with danger.

My second attempt to photograph Salt Water Crocs was in Papua New Guinea where an ex-pat diver organized a very small juvenile croc from a croc farm to be released over a coral reef. It was productive but very unsatisfying. Not unlike taking photos of tigers in a zoo. So with the help of a friend in Port Moresby I set about photographing “real” crocs in a remote area in Milne Bay.

One thing that PNG has is lots of rivers due to the rugged mountain interior trapping rain clouds and sending their contents down to the sea. Huge inland swamps form and are ideal places for crocs to breed and feed. However when things get crowded, weaker crocs of all sizes are forced out into the rivers. When all of the space there is used up territorial disputes force the losers out of the river systems into the coastal areas where they seek out less crowded estuaries and rivers. My plan was to find these ‘transient’ crocs in relatively clear coastal water (the rivers usually have the viz of thin gravy) and get into the water with them.

A lot of time, energy, patience, anti-itch cream and malarial prophylactics were thrown at the problem of finding these subjects before Mike and I were able to find, with the help of local residents, some of these rather nervous transient crocs. When we first slipped over the side of our small boat and swam towards our first croc the three local guides we had hired rolled their eyes and tutted through their teeth as they voiced their opinion of those mad white guys swimming with crocs that attack and kill villagers on a relatively regular basis.

Swimming into the general area where the croc had been spotted we spread out to comb the area of flat reef flat covered in coral clumps and patches of tattered weed. Viz was a relatively massive 4-6 meters and depth varied from 20m and more on the seaward edge but averaged around 4 meters. Mike’s imitation, through his snorkel, of a flatulent elephant alerted me to the discovery of our crocodile. Lying amongst the short weed the 2 meter croc looked like a water-logged tree trunk. Its slitted eyes were open and, though they never



Crocodiles swim with a flowing motion, using their hips to move their long sinuous tail. Nikonos V, 15 mm lens, Velvia, f5.6@1/125, strobe fill, manual exposure.

moved, we had the distinct impression that it was watching our every move.

Taking a breath I dived down and approached from directly in front. Crocs attack their prey underwater by swinging their head to the side with a rapid slash so a front or rear approach are the safest zones to use. Using the rough reef surface I slowly and quietly pulled myself along until I was within a meter the croc. It did not move a muscle. It could have been made of concrete. Pushing a touch closer I began to shoot. I was down for about a minute then pushed back and up to take a breath and allow Mike to have a try.

Over the next 15 minutes not once did the croc move or adjust it’s position. Then as we both watched from the surface it pushed up with its front clawed feet and swam, turning away from us, with a sinuous hippy sway towards the surface. When the nostrils cleared the surface it relaxed,



Crocs may "hang" at the surface for quite a long time. This may be to increase their body temperature using the sun and the much warmer surface layer and/or to check out any surface activity. Canon F1, Aquatica housing, 20 mm lens, Provia, f11 @ 1/60, manual exposure.

This large adult was found resting on the seabed on a reef which extended out to sea from a shoreline riddled by rivers. Canon EOS3, custom housing, 20 mm lens, Velvia, f5.6 @ 1/60, manual exposure.



This small juvenile was photographed resting on cabbage coral on a shallow island reef situated about 1 kilometre from a river mouth in Papua New Guinea. The open mouth is a threat posture in response to my close approach. Nikonos V, 15 mm lens, Velvia, f5.6@1/15 manual exposure, strobe fill.



allowing its legs and tail to hang down as it took a series of breaths. Raising my head above the surface I could see it watching me with its yellow slitted eyes. Swimming in towards it I received the first reaction from our croc as it dropped open its jaws, showing an array of impressive teeth, and hissed at me like a snake. Not blessed with a total disregard for my appendages I backed off. The croc did not swim away but continued to hang at the surface, watching our every move and

taking the occasional breath through its nostrils.

With a minimum amount of fuss it slid its protective “goggles” across its eyes and dropped back down below the surface, diving towards the seabed with that classic hippy swimming motion. As it reached the bottom it dropped its hind legs and began to run across the seabed looking for all the world like a dinosaur out of a Hollywood movie. Finding a spot to it’s liking the croc glided to a halt, using it’s smaller front legs to break and prop.

I call the croc an “it” because the only way to find out the sex of a crocodile is to put your finger up its vent and feel for a penis. I had not gone through that process with this particular crocodile partly because I felt uncomfortable fumbling for a penis up someone else’s bum and also I assumed that the croc, male or female, may not fully appreciate my curiosity.

Over about 2 hours Mike and I followed the croc, shooting when we could. At no time did we feel in danger though there was a few moments of anxious back peddling when it propped on a porites coral mound at the surface and the current pushed me a little too close. We were careful not to harass our subject as even though these animals can be ferocious predators they are also sensitive to stress. Professional farmers and handlers know that even a large croc can die very quickly if subject to excessive stress.

Crocodiles seem to be the flavour of the month with TV programs and movies depicting crocs attacking animals and humans with apparent blind ferocity. As is always the case the truth about these magnificent predators is far more complex and compelling than such a simplistic view. That said I would never suggest that the average diver seek out crocodiles but to treat them with the caution and respect that they deserve.



A large adult around 2.5 m long lived for a short time between two river mouths. It was quite possibly evicted from river territory by stronger and/or larger crocs. Milne Bay, Papua New Guinea. Nikon 801S, Aquatica housing, 20 mm lens, Provia, f11 @ 1/60, manual exposure.



Baby crocs use a sharp hook on the tip of their snout to open their leathery shell. This hatchling was shot in an inland swamp. It was ready to bite even before exiting it's shell. Canon EOS3, 100 macro, f32 @ 1/8 sec

Kelvin Aitken

All images © [marinethemes.com/Kelvin Aitken](http://www.marinethemes.com/Kelvin Aitken)
email: info@marinethemes.com
<http://www.marinethemes.com>

Subtronic Alpha

Overspecified and underpriced

This is the Subtronic Alpha.
It is one of the finest underwater flash units in the world.
Yet it costs surprisingly little.



It's equally at home in the hands of a beginner or a pro.

It provides automatic TTL exposure with the Nikonos V and RS and most housed cameras

For more creative lighting you can override the TTL anytime you like and choose from seven manual power settings for fine discrimination. Its up to you.

To ensure you don't miss shots when the action is fast and furious the Alpha recycles in under three seconds.

There's plenty of power with the Alphas high guide number of 28. And you won't need a light sapping diffuser when you shoot wide angle. All of that power is available to you with full 100

degree coverage.

The built in power pack lets you shoot five rolls per charge and recharging via the multi voltage smart charger takes just two hours.

The Alpha has an aiming light fitted in the reflector as standard. Switchable underwater between 7 and 10 watts, it's brighter than many primary dive lights and can be used for night diving. And it doesn't stop there. A safety beacon and slave are standard features on the Alpha.

The gun is hand assembled and protected by a 100 metre depth rated aluminium body.

And you won't even get nickled and dimed on accessories. The Alpha comes complete with charger and cable. **And all for just £799.00.**



Ocean Optics

13 Northumberland Avenue, London WC2N 5AQ

Tel 0207 930 8408 Fax 0207 839 6148

Turning into Voyeurs!

Story © Beth Tierney
Pictures © Shaun Tierney

It wasn't quite what we'd intended - to sit and watch others indulge in that which should really be kept private, but it's precisely what we did. It was 6pm on Kapalai Island and we were attending a peep show of a very special nature. Every night, just after sunset, you can slide beneath the jetty and see droves of tiny mandarin fish creating babies.

Beauty in miniature

We've been to many famous muck-diving sites and always hoped to see these intensely pretty little fish. And although we have often had a glimpse of them, actually capturing them on film has been much harder than almost any other subject we've come across. Shyness is an integral part of their nature. Mandarin fish keep very much to themselves, living in stable colonies amongst the cracks and crevices in coral rubble. There's plenty of hiding space and food is easy to come by.

But even if you know all that, spotting these members of the dragonet family is still pretty difficult. Until you put a light on them, they are just grey flitting shadows and only their latin name, *Synchiropus splendidus*, hints at their extravagant skin colouring. As adults they are rarely more than five centimetres long and when they do come out to play, they are only in the open for the time it takes the sun's fading rays to give way to complete darkness. All this adds up to the fact that finding them is nigh on impossible, so going to a place where there are known colonies ups your chances. And what helps even more is having a divemaster who has perfected a technique for introducing them to photographers.

It's all in the knack

Northern Borneo is mostly known for the magnificent walls and schooling pelagics off

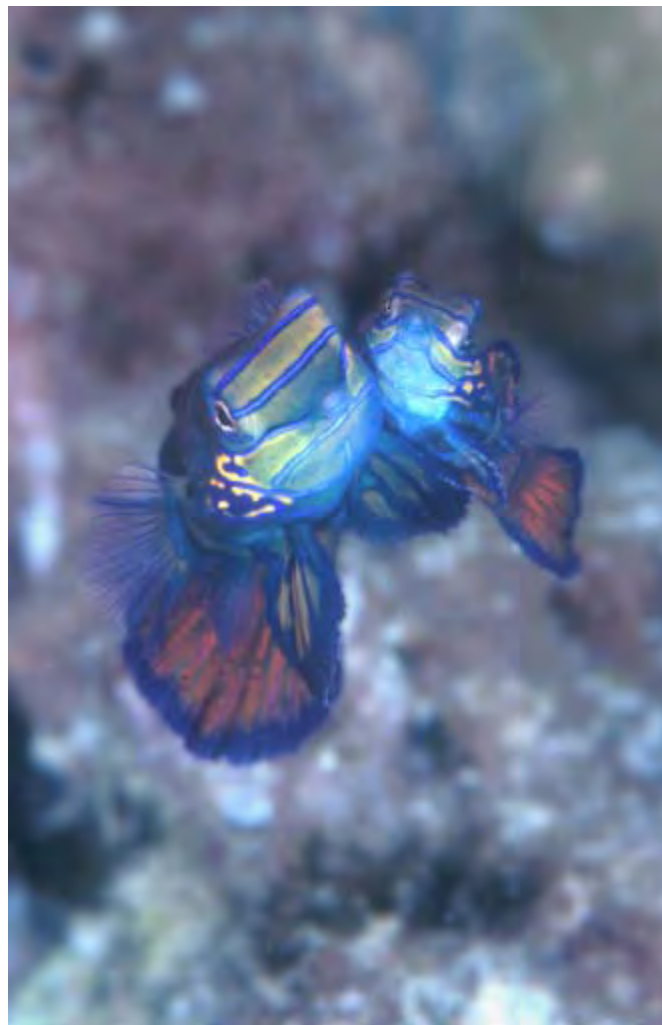

Sipadan Island. Following hot on her heels, is neighbouring muck heaven Mabul. Nearby Kapalai is just a sand spit of an island, but one that's gaining it's own reputation for rare and unusual marine treats.

We leapt into the water from their dive jetty, and our divemaster led us just a few metres downwards, then signalled for us to stop. We could just make out the crew's shadowy feet cooling in the water above our heads. Our eyes adjusted as we sat patiently waiting for the light to fall to precisely the right level. Once it did, more than a dozen mandarins emerged from their lairs and started their evening courtship ritual. The tiny fish were dashing around, greeting their friends and pecking at the tiny crustaceans they feed on.

When he judged the time was right, divemaster Dodong turned on his Q40 torch but wrapped his hand tightly over the lens. Only a tiny bit of light leaked between his fingers as he followed the vague movements.

We'd glimpse two little shadows approaching each other, a larger male and a smaller female. Sometimes, she would back away but if she

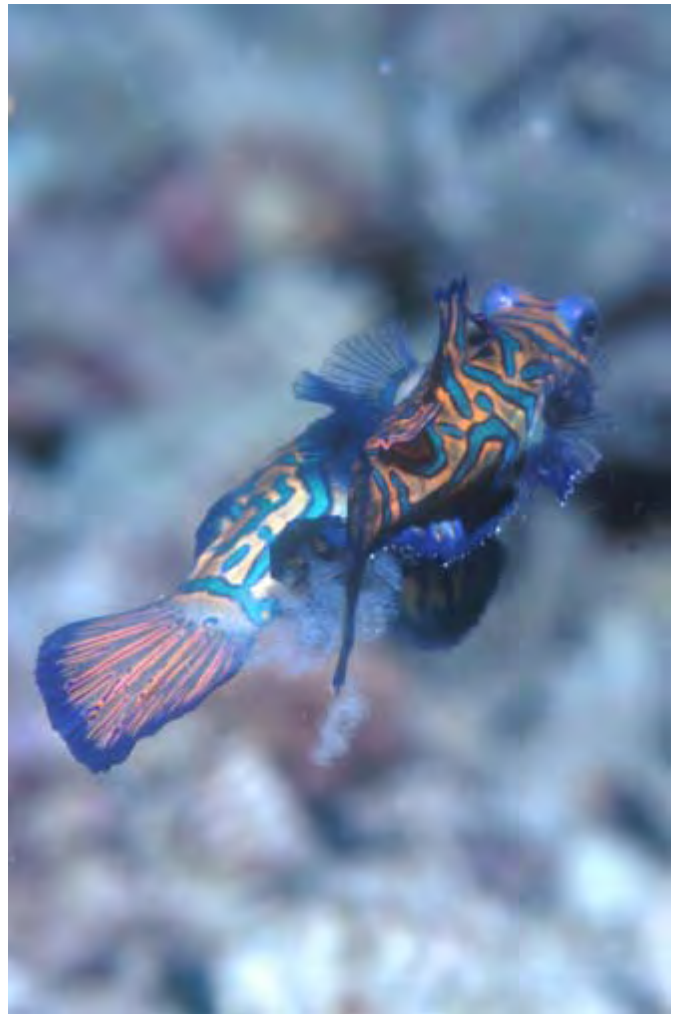

All photos taken with a Nikon F90X, Sea & Sea housing, 60mm macro and 105 macro lenses. Fuji Provia to improve F stop. F16, aperture priority. Twin Ikelite 50 strobes.

fancied her suitor, the pair would rise upwards through the water until they were about 18 inches or more above the reef. Dodong would quickly spread his fingers and flash the torch beam onto them.

First roll down

We watched this process a few times, and saw how the system worked. With Shaun sitting between us, Dodong and I would make eye contact, watch a courting couple, then follow them up in the water column, hoping desperately that both Shaun and the camera focused on the lovers before our intrusive beams scared them off.

Twenty two minutes, 36 frames and a lot of mandarin kisses later, we exited the water grinning from ear to ear. Weid had as much fun as those little guys seemed to! Well, almost. As we

wandered back to our cabin, Shaun told me he had seen something floating in the water, the shutter would drop back down while I was still peering through the viewfinder and I could see a puff of white. Do you think that's eggs?

Only the best

A couple of nights later we headed back down to repeat the dive with the 105 lens. Knowing the system, we took a more leisurely pace and watched the interactions between the group. The girls were picky - not just any male would do. Several fish would be happily feeding when a larger male would make his first approach. Sometimes a pair would rise upwards only a few inches but the suitor would be rejected with a quick kiss and the female returned to her dinner.

Occasionally two males would appear to fight

over a favoured lady, a younger, less experienced male trying to muscle in on the action. But each female seemed to know when the man of her dreams had arrived, and accepting his proposition, the pair would swim up through the water with the lady resting on her lover's pelvic fin. After maybe five seconds, and at the height of their swim, they would pause for a brief moment, then disappear at the speed of light.

Hard evidence

As we followed the progress of courtship and mating between these tiny critters, Shaun noted again the blur of white left behind when they dipped back down to safety. However, it wasn't till our return home that we saw the proof. The cloud of white had indeed been mingled eggs and sperm.

We learnt that mandarin fish are the smallest of all marine species to spawn into open water. Like other spawners, they produce millions of eggs, but their parental duties are over once they're deposited into the water. The eggs drop down into the cracks of the coral and are left to grow into larvae. By projecting our images up, we even found a few frames with egg trails slipping from the female body. Not only had we become willing voyeurs, we'd witnessed the birth of a new generation of these exotic reef dwellers.

Story © Beth Tierney
Pictures © Shaun Tierney



Just a few minutes by boat from Sipadan, but a full world away, lies the exhilarating Sipadan-Kapalai Dive Resort.

Macro heaven in the Celebes Sea

Sitting over Borneo's Ligitan Reefs, this romantic water village perches beside a mile-long sandbank of pure white sand. No bugs, no noise and no crowds, just some of the best diving and photographic opportunities right outside your bungalow.

For more information visit our website <http://sipadan-kapalai.com> or email psrt@po.jaring.my

Images © www.seafocus.net

Aquarium Photography

by Jurgen Brauer

What to do when the photography urge itches but you can't get wet? Answer: grab your camera gear and go to a nearby aquarium. And grab your diving gear just in case: some aquariums, as my daughter and I found out, do let you jump right in.

Many aquariums of course recruit volunteer divers for fish feeding and tank cleaning duties. That is a good option for local divers. But what's the traveler to do? We have found, to our delight, that you do not always have to be in the water to take interesting "underwater" photographs. The jellyfish tank on the cover page - this one in Cape Town's Two Oceans Aquarium - certainly evokes plenty of underwater memories. More on Cape Town later in the story.

I report on three very different kinds of aquariums. The first is the venerable Berlin Aquarium which we visited in the summer of 2002. Opened on 18 August 1913, the year before World War I, it is actually aquarium, terrarium, and insectarium all in one. Built adjacent to the Berlin Zoo smack in the city center, it is among the oldest aquariums in the world. Despite substantial rebuilding after World War II, its age shows in the somewhat constrained layout of its three floors. The main floor consists of what seems like hundreds of mostly smallish tanks, and the floors upstairs contain vast numbers of large and small terrariums, packed with reptiles,



raggedtooth.jpg [144dpi; 567h x 756w pix; flash; 12mm; F/2; 1/50sec; ISO-100]

amphibians, and insects. You walk the aquarium the way you walk the British Museum: until your feet fall off, so overwhelmingly species-rich is the place. Indeed, it is one of the largest of its kind in the world. In return, you are provided with a

gamut of photographic opportunities from safely-ensconced poison-dart frogs to equally safely-distanced giant crocodiles kept in the courtyard to tarantulas and stick insects to rare stonefish and every exotic creature you ever wanted to see



kelp.jpg [144dpi; 567h x 756w pix; flash; 7mm; F/1.8; 1/30sec; ISO-115]



salmon.jpg [144dpi; 567h x 788w pix; no flash; 7mm; F/1.8; 1/13sec; ISO-200]

All pictures taken with an Olympus C-3040Z digital camera, using an Olympus PT-010 housing for the underwater photographs. The focal-length data is digital. 7mm digital corresponds to 35mm and 21mm digital corresponds to 105mm for a 35mm film camera. The kelp and shark-tank pictures were taken with an Inon UWL-100 wide-angle lens attachment that screws onto the PT-010 housing.

and photograph.

Photography through the glass offers no apparent problem, as the sample shots of the mudskipper [mudskipper.jpg] and the snake [snake.jpg] illustrate. We avoided glare by gently putting the rim of the camera lens right on the acrylic glass and then do the focusing, checking the desired effects via the screen of the digital camera (an Olympus C-3040Z). Be careful not to slide the lens rim across the glass as it may scratch the acrylic surface. Some subjects sit right by or even on the glass so that you can do macro photography as close up as the width of the glass.

Depending on the species in the tank, light is often ample but you cannot provide additional light to eliminate shadows or highlight features that caught your interest. You have to work with what the tank and the species offers you at that moment. We have not tried it but one may be able to use a tripod placed close to the glass and use a remote shutter release for long exposure of “dark” tanks. Putting your lens rim on the glass also means that you may not be able to capture larger or active subjects. A wide-angle lens and fast shutter speed might help.

An entirely different sort of visit was not to an aquarium per se, but to an exhibit of mountain lake ecology housed in the 14th century Chateau de Annecy overlooking the small village of Annecy, France, near the French-Swiss border.

On a business trip to give a lecture in nearby Grenoble, an opportunity came up on the preceding weekend to see Annecy, a lovely small town in the region of Savoy. In the town

castle, I discovered the ecology exhibit and a tank full of bunched-up lake salmon proved irresistible to photograph [salmon.jpg]. I took the picture through the glass, using long exposure. In our travels, we have come across small exhibits such as this one from time to time. Since you are likely to have your camera gear with you, don't overlook the "underwater" photographic opportunities these exhibits provide.

Berlin and Annecy are interesting contrasts - one is a major world city, the other a small village nestled against the Alps - but both leave you dry. In contrast, the relatively new Two Oceans Aquarium in Cape Town - opened in the mid-1990s - is one of the few in the world where you can sign up for a regular dive in one or both of their big tanks.

One, the kelp tank [kelp.jpg], sported a frigid 55 degrees Fahrenheit and was stocked with an assortment of species that fairly mobbed us as soon as they got "wind" of the treats we brought along. Since there is a good bit of surge, you do need advanced diving skills to keep away from the kelp and the easily-scratched acrylic glass. Otherwise, it's plenty of sheer fun to swim around in circles and experience a half-hour in the life of aquarium fish. Children trooping through the exhibits squished their noses against the glass and watched us big-eyed. Parents waved happily as we photographed them and their children.

The Cape Town aquarium leases space on the aquarium roof to an incredibly nice fellow by the name of Zaid Manchest. He conducts the daily dives (at 10am, 12n, and 2pm) which are



jellytank.jpg [300dpi; 1770h x 1329w pix; no flash; 7mm; F/1.8; 1/8sec; ISO-200]

preceded by a half-tour introduction, the inevitable diving paperwork, and suiting up. (Bring your own equipment or rent it.) The aquarium highlight by far, proved to be the second tank, the shark tank. Stocked with cownose stingray, a hawksbill turtle, smaller shark species, and plenty of other fish, its most prominent inhabitants are four female and one male Sand Tiger sharks (also known as Ragged-Tooth sharks) of impressive size. We entered the 5-meter (15 feet) deep tank from the aquarium roof, gently sliding

off a diving platform near the inner tank wall, and quickly descended to the bottom. Keeping our arms and legs well tucked in, we crouched along the bottom of the tank for our allotted half hour. The sharks are well-fed of course but on occasion, Zaid said, a fish or two go "missing." A special feeding on Sundays gauges how hungry they are. Our dive was Friday? and we did a second one Saturday morning.

On the first dive I was overly cautious, hugging the tank bottom. Since the sharks were in

the middle of the water column, use of the flash overexposed their nearly white underside against the surface light. After reviewing the shots later that day on the laptop computer at the hotel, it turned out that I did not get any good shots at all. We begged a second dive off Zaid, and discussed our photographic needs with him. Graciously, he accommodated us and gave us a private Saturday morning tour - and showed off an incredible antic to boot: he swam up to a Sand Tiger, gently touched it under its chin, slid his hand into its mouth, pulled out a tooth, turned around, and gallantly handed it to an unbelieving Anne. Then he turned in my direction - I had drifted to a mid-water column position along the outer wall to photograph the event - and pointed to something behind me. I am sure you know the feeling: undefined, yet something's definitely up. I turned and saw a Sand Tiger calmly heading straight for me. "Well," I thought, "I might as well take a picture."

[raggedtooth.jpg]

Shooting wide-angle from two feet away, it's no secret to me anymore why the Sand Tiger also goes by the name of Ragged-Tooth shark! In the event, the fellow passed me quite unperturbed. I guess he wasn't hungry. Actually, Sand Tigers are thought to be relatively non-aggressive toward humans. Still, they are sharks, and these guys were running at 2 to 2.5 meters (8-9 feet) in length.

I wanted to take an evocative shark picture but had the following photographic problem. As is well-known, the biggest digital camera problem is the shutter-delay of as much as one second between pressing the



snake.jpg [144dpi; 567h x 837w pix; no flash; 10mm; F/2; 1/30sec; ISO-124]



mudskipper.jpg [144dpi; 567h x 756w pix; no flash; 17mm; F/2.3; 1/60sec; ISO-100]

shutter button and the picture being recorded. Meanwhile, the subject moves. One solution is to pan the camera with the subject. But in low-light conditions, there is the additional problem of needing a long exposure time. So now you are panning while the shutter stays open and you may get nothing but streaks. Exposure time is reduced with the use of the flash, but the powerful digital

flash has only limited strobe-setting controls and easily overexposes the subject. My solution [sharklight.jpg] was to distance myself from the shark so that the build-in flash would not reflect off the subject but would trick the camera electronics to select a high shutter-speed, combined with a wide F/2.6 aperture and high-speed "film" (at ISO-400). The

result is close to what I wanted: a Sand Tiger silhouette solely defined by the overhanging aquarium lights. You don't so much see as feel the shark.

The Cape Town aquarium is very modern. Plenty of space, lots of educational exhibits, a touch tank that sports a completely unafraid sea anemone, stretching out its tentacles as if to welcome you, and a cool rig that focuses a microscope onto feeding coral. The microscope is hooked up to a video camera which, in turn, is hooked up to a TV monitor. The attendant drops nutrients in the water, and you watch the polyps extend and feed. Unfortunately, I did not have an adapter with me to photograph the polyps through the microscope eyepiece.

One of the advantages of aquarium photography is that you do get to photograph species you are unlikely to encounter in the wild. Take the huge, and aptly named, Giant Spider Crab for instance which ordinarily lives at depth below 50 meters (150 feet). Anne and I had met a truly giant specimen - surely five feet in diameter - at the Zoological Museum at the University of Cambridge in the summer of 2002, but it was a special treat to capture a live one on film [giant.jpg]. The one pictured here measured perhaps near three feet in diameter.

Note the purplish light which simulates reduced sunlight at depth: it's not a digital effect playing with Photoshop color adjustment levers.

The lesson then is simple: next time you itch for "underwater" photography, don't forget to check out the nearest aquarium while you travel.



sharklight.jpg [144dpi; 567h x 841w pix; flash; 21mm; F/2.6; 1/100sec; ISO-400]



giant.jpg [144dpi; 567h x 756w pix; no flash; 7mm; F/1.8; 1/100sec; ISO-200]

Jurgen Brauer and daughter Anne

Economics professor Jurgen Brauer and 11th-grade daughter Anne discovered u/w digital photography in Bonaire in December 2001. They have since traveled and photographed in Cozumel, the Azores, and South Africa.



[Photo: Zaid Manchest.]

HMS Royal Oak video



“a workmanlike, professional production, and worth viewing”

John Bantin, Diver magazine

The wreck of HMS Royal Oak in Scapa Flow is a designated war grave and all diving is prohibited but in 2000 a special permission was granted for the wreck to be filmed as a moving tribute to all those who lost their lives.

This new professionally produced 50 minute video includes underwater images of the wreck which have never been seen before and there are interviews with survivors and Orcadian Sandy Robertson who was the first diver to go on the wreck the day after she sank. Also included is coverage of another unique event when the ashes of Dorothy Golding, wife of Bandsman Arthur Golding, who went down with the ship, were taken down by her grandson, Christopher Kilford, and placed in the wreck to reunite the couple.

The finale is the unfurling of a battle ensign on the upturned hull by a Royal Navy diver on the anniversary of her sinking and the final credits include the names of all those who died in the tragedy.

Running time 50 minutes. Narrated by Tom Fleming. Produced by Ocean Optics Ltd. Directed by Peter Rowlands

The video costs £16.95 (+£2.50 UK postage). Total £19.45. Please send cheques payable to PR Productions and send them to: Royal Oak Video, 13 Langley Avenue, Surbiton, Surrey KT6 6QN. Credit card tel & fax 020 8399 5709

<http://www.hmsroyaloak.co.uk>

I ordered the video and it arrived last Monday. I've only had a chance to view it today. I was so profoundly moved (and I am a hard bitten first world war historian) that I had to email you.

I was impressed with virtually all aspects. I thought the balance between interviewees, diving footage and historical context was spot on. This is something not always achieved in documentaries - I know because I used to make them. The interviews with the survivors threw the whole affair into stark relief. I cannot praise this video highly enough. And I thank you for your web site.

**Warm regards
Pamela Armstrong**

Antibes Film Festival cuts the mustard

Alex Mustard did rather well in this years Antibes Film Festival and he told UWP how three of his successes were achieved.

This picture finished first in the black and white pictures. It is my least favourite of the photographs I entered into the Antibes Festival - which I guess shows how subjective picture judging is! I took this picture at the wreck of the Oro Verde in Grand Cayman. I used my Nikon F100 + 28-70mm in a Subal housing and two Subtronic Alpha flashes. The film was Kodak Elitechrome "extracolor" (colour slide!) I drained the colour from the image on the computer before printing. Exposure was on aperture priority (f22), with slow, rear flash synch at (1/2 sec).



This picture was second in the same category. This picture was taken at dawn at the Sandbar on Grand Cayman. I used a Nikonos V with 15mm lens, shooting on aperture priority at f5.6 with no flash (shutter approx 1/30-1/60th). This picture was also taken on colour slide and as such, is rather flat and unremarkable. But I liked the composition so decided to have a look at it in black and white on the computer. The resulting image is one of my favourites.



The Antibes Film Festival 2003 will be from 26th October until 2nd November

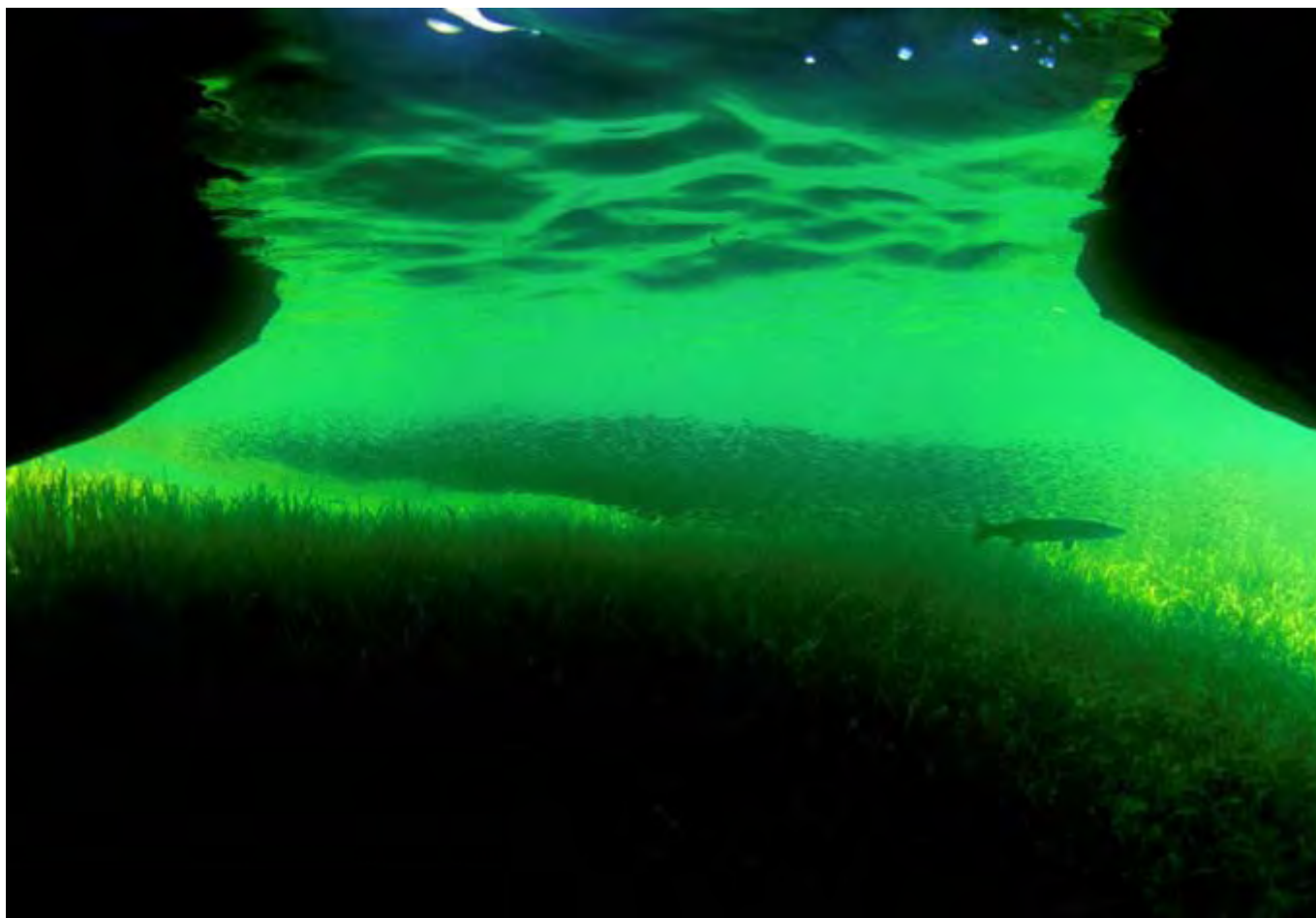

This picture was third in the colour print category. It was also taken on same two week holiday in Grand Cayman this summer. I took this shot while snorkelling (see UWP 3: 40-41) under the dock at the Ocean Frontiers Dive Centre at the East End of the island. This picture was taken with my Nikon F100 + 16mm FE in a Subal housing with no flash. The picture shows a barracuda hunting silversides in between two dive boats. I took this picture on aperture priority at, I guess, f8 @ 1/60th? It amuses me that I was able to take such a green image in a clear, blue water paradise like the Caymans! This category was won by Italian Alessandro Tommasi.

Have you seen a Nikonos V like this?



The green Nikonos V normally has the metal body painted green but I recently had this camera in for repair which had the body painted black (like the red/orange model).

Has anyone else seen such a model or is it a one off (and therefore collectable?!)

Any help would be appreciated. E mail me peter@uwpmag.co.uk

Advertising in UwP

UwP is fast becoming THE magazine for underwater photographers worldwide. The astonishing capability of the internet makes each issue of UwP available to the world without any printing or postage costs.

This makes UwP the ideal vehicle for advertisers. Underwater photo equipment manufacturers, distributors and retailers can now reach a worldwide audience. Also dive travel agents and resorts can attract more underwater photographer clients.

Each issue of UwP is downloaded on average by over 28,000 readers.

Finally, UwP is the only magazine, bar none, which can claim that 100% of their readers are underwater photographers! That's the perfect target audience.

For full details of our low rates please contact Peter Rowlands, PR Productions

peter@uwpmag.co.uk

File Downloads

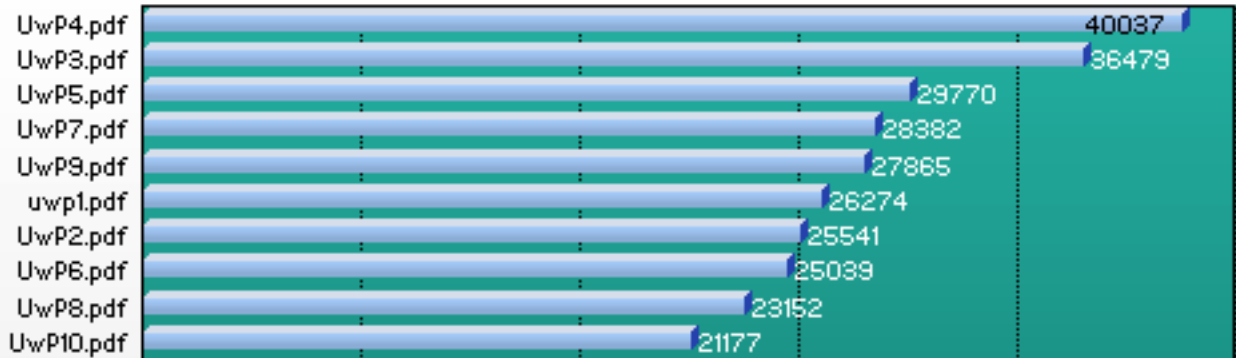

Countries

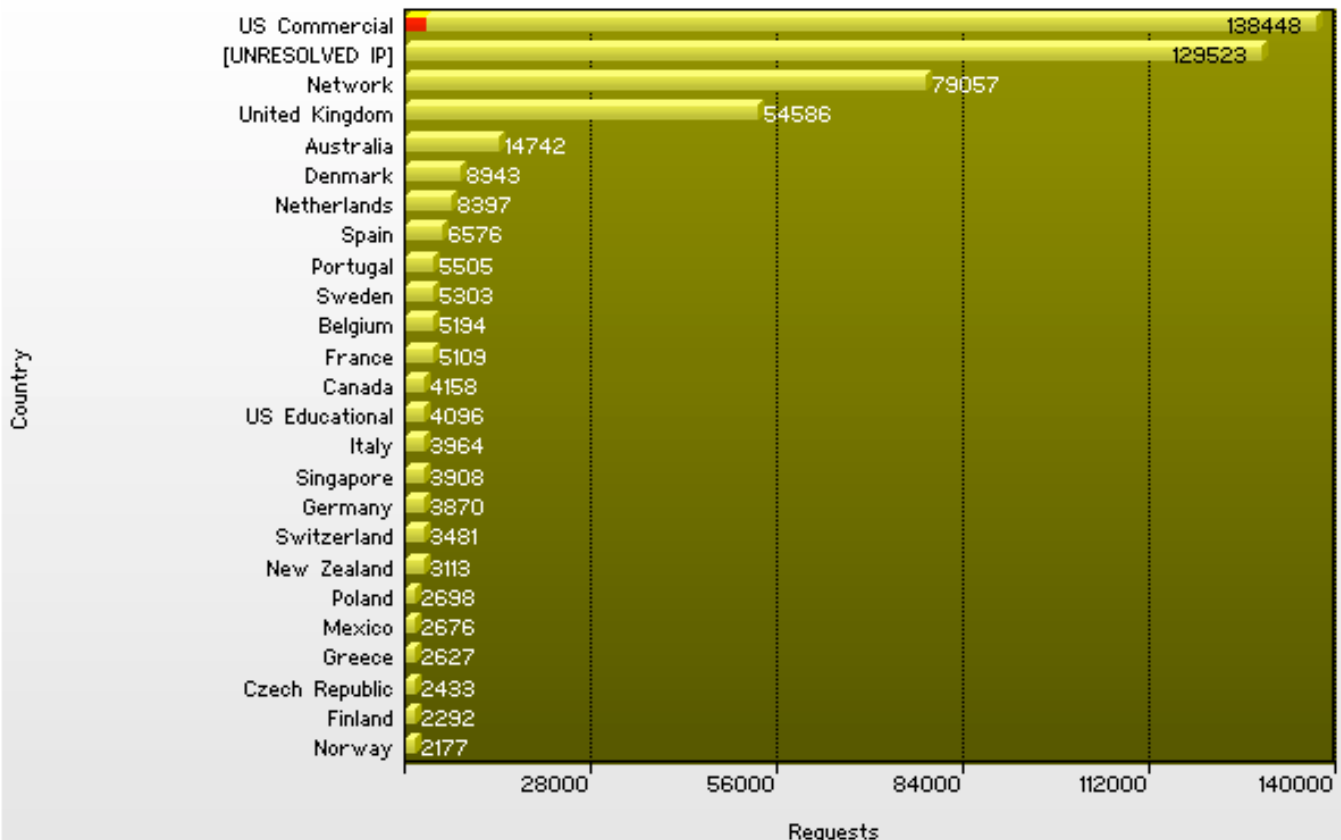

Underwater Photography

a web magazine

Guidelines for contributors

The response to UwP has been nothing short of fantastic. We are looking for interesting, well illustrated articles about underwater photography. We are looking for work from existing names but would also like to discover some of the new talent out there and that could be you!

The type of articles we're looking for fall into five main categories:

Uw photo techniques -

Balanced light, composition, wreck photography etc

Locations -

Photo friendly dive sites, countries or liveaboards

Subjects

Anything from whale sharks to nudibranchs in full detail

Equipment reviews -

Detailed appraisals of the latest equipment

Personalities

Interviews with leading underwater photographers

**If you have an idea for an article,
contact me first before putting pen to paper.**

My e mail is peter@uwpmag.co.uk

How to submit articles

To keep UwP simple and financially viable to produce we can only accept submissions by e mail and they need to be done in the following way:

1. The text for the article should be saved as a TEXT file and attached to the e mail

2. Images must be "attached" to the e mail and they need to be:

Resolution - 144dpi

Size - Maximum length 15cm i.e. horizontal pictures would be 15 cm wide and verticals would be 15cm.

File type - Save your image as a JPG file and set the compression to "Medium" quality

This should result in images no larger than about 120k which can be transmitted quickly. If we want larger sizes we will contact you.

3. Captions - **Each and every image MUST have full photographic details** including camera, housing, lens, lighting, film, aperture, shutter speed and exposure mode. These must also be copied and pasted into the body of the e mail.

We pay a flat fee of £50 (+VAT if invoiced).

I look forward to hearing from you.



For sale

Subal CP5 with Nikon 5000 , Spare Battery, 512 MB Card £2000 ono. Ultralight Arm with mounts £200 ono. Brand New single and dual sync cords £60 or £120 Everything in as new condition, Please phone 07855 961516 (daytime) or email MichaelWhy@hotmail.com for full details

For sale



Subal housing for Pentax LX, camera, winder, v/finder, 24mm, 50mm Macro lenses, ports, Isotta K-50 flash, Subal arm. Housing, flash, as new. Camera, lenses, VGC. Superb, compact outfit with full-frame viewfinder. Photos, details via e-mail. Aust.\$4,700- (neg) +p/p from Australia. Can sell housing separately. E-mail: Sam at kabir@chariot.net.au'

For sale

Happyfish T-shirts and Freediving gear .Helping the Shark trust. Look at www.happyfish.tv

For Sale

Complete Mamiya medium format (120 film 6 x 7 cm image) underwater camera system.

Ocean Optics RB67 housing. all gears & accesories included 2 ports 1 fisheye, 1 Correction port (Peter Scoones type)

Mamiya RB67 camera body 37mm fullframe fisheye lens 90mm lens (for macro & normal) 2 film magazines (120 & 70mm) 2 Oceanic 2003 Strobes with EO connectors. Flight case (holds everything above)

Everything for £2000. - Yes you read it correctly. Contact John Butler at jb@faglab.no or phone ++ 47 70 13 82 60 monday - Friday, between 8 a.m. - 3 p.m.

Classifieds

For sale

Nikonos III w/35 mm lens Ikelite 50 Substrobe w/Mini C torch TTL Cable, Mounting tray with arm and attachments Manuals for all Perfect condition, very few dives Complete kit for 500.00 pounds Contact: Tom Green Phone: 01475686970 Mobile: 07968616860

For Sale

Sea&Sea MX-5 underwater camera, Hardly used, £75. Email: Ali@TheHomeland.co.uk Or Tel. 01494 522282.

For sale

Sea & Sea MX10 Wide angle, macro and close up lenses. Lens carrier, YS40 strobe, UV filter. Good condition. £350.00. Sea Quest integrated weight BCD (Med/Large) Used only once, perfect condition, Only £200. Phone 01908 696955 or email david@display-creatives.co.uk

For Sale



SeaCam Pro housing Canon EOS5, double strobe connection, moisture detector, SeaCam SeaFlash 350TTL, all connectors, gears, arm, chargers, cleaning kit, spares; 3 dome ports, carry case. SLR available if required £1,499. Contact: julie.howell@hp.com

For Sale

Subal universal dome. As new. Fits lens as wide as 18mm. £300 Unused Subal aperature gear. £30 Contact Tony: Tel: 01209 821731 or e-mail: tsu7777@aol.com

For sale

Good working condition. Some barely used. Price (U.S. \$) does not include shipping.

Nikonos RS \$2175

Canon EOS 3 with PB-E2 power booster \$960

Nikon F100 \$795

Nikon F3 action finder, motor drive \$690

Nikon F90 \$440

Nikon FM2 \$275

Nikonos V \$350

Nikonos 15mm lens with viewfinder \$1095

Nikon 20-35mm AF f2.8D zoom \$835

Nikon 300mm EDAF f4.0 \$750

Hasselblad SWC/M with 38mm \$2490 Aquatica 4 housing for Nikon F4s with moisture alarm, \$890; or \$1455 with dome port, macro port, port extension, gear rings, etc.

Seacam Nikon F90 housing with pro viewfinder, dual strobe sync connectors, SCM switch & moisture alarm, macro systemport with optical coating, two optical glass dome ports, port extensions, assorted gear rings and other accessories, and Ultralight strobe swivel ring \$4500

Ken-Labs KS-4 gyro-stabilizer kit \$950

Nikon telextenders:TC-14B \$225; TC-201 \$117; TC-301 \$230

Doug Perrine, doug@seapics.com, fax +1-808-329-6659, tel 329-0253

For sale

Complete Light & Motion Stingray Travel Package comprising: Sony TR2000 Hi-8 Camcorder, all accessories and many tapes Pelican case. Stingray housing, batteries, lights, chargers, optical and colour video backs and spares Perfect order - not used since factory service. £900 ono

Keith Thomas

home 02087860551

work 01293573528

keith.thomas@srg.caa.co.uk

For sale

We are offering a variety of used underwater and topside photography gear for sale: http://www.oceanlight.com/for_sale.php including two Nikon F4s bodies, a Subal housing for F4s with macro and dome ports, seven strobes, a Clearlight 3-projector dissolve/programmer and a four-track studio recorder. Solid gear here that has taken some great images for us and can do the same for you. http://www.oceanlight.com/for_sale.php

For Sale

Subal Housing for Nikon F5 with Actionfinder. Excellent condition. With handle, two flash plugs (for Nikon SB28) and spare 'O' rings. No ports. Owner converting to digital. £1,250.00 ono. Phone Peter Rattey 013398 85640 after 18:00. Free shipping. rattey@btinternet.com

For Sale

Nikonos 5 body, SB105 Flash and Nikon Mounting Kit, 28mm f3.5 Nikonos Lens plus DF 12 UW Viewfinder, Nikon Close Up Kit (with carry case), All items in pelican case and Nikonos kit bag. All items are brand new never used. £1850 ono. Contact Tel: 01577 830024 or email adrian.oxley@fmglobal.com

For sale boxed

Nikonos V with 35mm lens, Sea & Sea YS50 TTL strobe, close up tubes and carry-all. Immaculate, camera recently serviced by Ocean Optics. Bargain £700 the lot. SE London. Contact martin-porter@beeb.net.

For Sale

Nikkor 20-35mm £550 inc VAT
Contact Peter Rowlands
020 8399 5709 (UK) or e mail
peter@uwpmag.co.uk

For Sale

2 Ikelite Substrobe 150 TTL strobes with rechargeable battery packs. £125 each. Buy both get a dual synch chord for free! Contact Jim on 01342 851 196 or email info@scuba-safaris.com

Photography Tours

World-Class Macro Photo Opportunities with our special limited tours.



Max. 10 photographers with 3 or 4 in-water critter guides. July & Aug 2003 & 2004. 7, 10 & 14 night tours. 8th year. 20 years diving St. Vincent. Fab boat, all-inclusive pkgs. Visit www.dive-st-vincent-scuba-diving.com email Deb Fugitt, uwtours@seahorsetales.com for info.

Photo courses

Martin Edge Weekend Underwater Photo-Courses

Year 2003

15th-16th February 2003

8th-9th March 2003

5th-6th April 2003

Small groups

Two days of full tuition

E6 Slide film processing

Indoor (heated) swimming pool photo exercises

Two nights accommodation and breakfast in a Bournemouth hotel

Own camera equipment is preferable however hire facilities available.

Cost of Course £165

Contact Martin or Sylvia on 01202 887611 or E-mail at Martin.Edge@btinternet.com

Book a classified in UwP

Each issue of UwP is downloaded on average by over 22,000 readers worldwide. That makes it the ideal way to buy or sell your equipment.

You can sell or buy your equipment for a flat fee of just £5 (or £10 with a coloured box surround or £15 with a picture) payable by Visa, Mastercard or cheque. Your advert can include up to 50 words and will be read by over 22,000 underwater photographers.

No other magazine can offer such a concentrated circulation.

We recommend that you use e mail as your contact address.

E mail the text of your advert to

classifieds@uwpmag.co.uk. You can include your credit card number and expiry date or fax it to 020 8399 5709 or send a cheque payable to:

PR Productions

13 Langley Avenue, Surbiton, Surrey KT6 6QN

Improve your image

Subal

The legendary housing of choice for many of the worlds top underwater image makers.



Subtronic

These are the ultimate strobes. With fast 2 second recycling, optional laser aiming light and



Nexus



Offering the most versatile macro system in the world today, Nexus make possible extreme close up photography unavailable from any other housing line.

Nikonos



The classic underwater camera. We stock the range and have a fully Nikon authorised workshop facility.



Bonica

The Snapper builds into a neat system capable of creative pictures down to 150 ft, even in low visibility. It's so simple to use and, with prices starting at just £129, it's stunning value for money. This really is a breakthrough in price and performance. There's no better

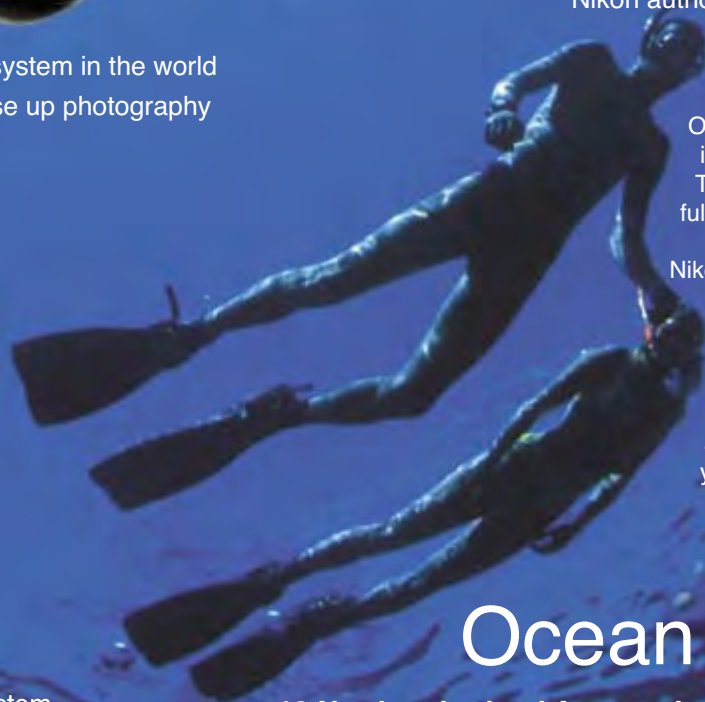

Our aim at Ocean Optics is to keep you shooting. That's why we provide a full servicing facility in our own workshops for all Nikonos, Nexus and Subal equipment we import. We even have loan equipment for those impossible deadlines! If you choose to be an Ocean Optics client, you will benefit from the best support in the

Ocean Optics

13 Northumberland Avenue, London WC2N 5AQ
Tel 020 7930 8408 Fax 020 7839 6148

Visit our web site for the latest news and special deals